

Law of behavior of reinforced concrete plates GLRC_DM

Summary:

This documentation presents the theoretical formulation and the digital integration of the law of behavior `GLRC_DM`, usable with modeling `DKTG`. She belongs to the models known as "total" used for mean structures (beams, plates and hulls). The non-linear phenomena, such as plasticity or the damage, are directly in relation to the generalized strains (extension, curve, distortion) and the generalized stresses (efforts of membrane, of inflection and cutting-edges). Thus, this law of behavior applies with a finite element of plate or hull. That makes it possible to save, compared to an approach multi-layer, time CPU as well as memory. The advantage compared to the multi-layer hulls is even more important, when one of the components of the plate behaves in a quasi-fragile way (concrete, for example), since the total model makes it possible to avoid the problems of localization.

The law of behavior `GLRC_DM` model the damage under membrane request and request of inflection of reinforced concrete plates, using "homogenized" parameters. This model of behavior thus represents an evolution compared to the model `GLRC_DAMAGE` who treats the damage only in request DE inflection. The structure of the model of damage of `GLRC_DM` resemble that of `GLRC_DAMAGE` and are both inspired by `ENDO_ISOT_BETON`. Contrary to `GLRC_DAMAGE`, `GLRC_DM` does not allow to model a possible plasticization, which returns it adapted less to simulate extreme loadings. Moreover, the behavior `GLRC_DM` is isotropic before damage: one neglects the orthotropism brought by the tablecloths of steel reinforcements.

One can plan to use the behavior `GLRC_DM` "only" on a modeling of plates to represent the reinforced concrete, or only to represent the concrete only by then associating it with modelings of grids of steel reinforcements, which makes it possible to represent the orthotropism and possibly it not symmetry of the tablecloths of reinforcements. This last choice simplifies also the parameter setting of this behavior.

Contents

1	Introduction.....	3
1.1	Total models.....	3
1.2	Objectives of the law GLRC_DM.....	3
2	Formulation of the model of behavior.....	4
2.1	Free energy.....	4
2.2	Generalized constraints.....	8
2.3	Thresholds and evolution of the damage.....	8
2.4	Digital integration.....	10
2.5	Operator of tangent stiffness.....	12
2.6	Change of reference mark.....	15
2.7	Calculation of dissipation.....	16
2.8	Internal variables of the model.....	16
2.9	Use of the model GLRC_DM in thermomechanical situations.....	18
3	Parameters of the law.....	19
3.1	Identification of the parameters of linear elastic behavior.....	19
3.2	Identification of the parameters of elastic behavior endommageable.....	21
3.2.1	Parameters of traction (keywords NYT, GAMMA_T).....	22
3.2.1.1	Threshold of appearance of the damage in traction NYT.....	22
3.2.1.2	Parameter of degradation of stiffness in traction GAMMA_T.....	22
3.2.1.3	Case distortion uniaxial pure.....	24
3.2.2	Parameters of compression (keywords NYC, GAMMA_C, ALPHA_C).....	24
3.2.3	Parameters of inflection (keywords MYF , GAMMA_F).....	26
3.2.3.1	Options RIGI_ACIER and PLAS_ACIER.....	26
3.2.3.2	Option RIGI_INIT.....	29
3.2.3.3	Option UTIL.....	30
3.2.4	Case traction-inflection uniaxial.....	31
3.2.5	Assessment of the identification of the parameters of the model GLRC_DM.....	32
4	Verification.....	33
5	Validation.....	33
6	Bibliography.....	33
7	Withnexe: Eigenvalues of the tensor of the deformations.....	34
8	Description of the versions of the document.....	36

1 Introduction

1.1 Total models

A model of behavior of plate known as total or element of structure, in general, means that the law of behavior is written directly in terms of relation between the generalized constraints and the generalized deformations. The comprehensive approach of modeling of the behavior of the structures applies in particular to the composite structures, for example the reinforced concrete (see Figure 1.1-a), and an alternative to the approaches known as local or semi-total represents, which are finer but more expensive modelings (see [bib5] and [bib6]). In the local approach one uses a fine modeling for each phase (steel, concrete) and their interactions (adherence) and in the semi-total approach one exploits the twinge of the structure to simplify the description of kinematics, which leads to models PMF (Multifibre Beam) or multi-layer hulls.

The interest of the total model lies in the fact that the finite element corresponding requires only one point of integration in the thickness and especially in obtaining a homogenized behavior. This advantage is even more important in the analysis of the reinforced concrete, since one circumvents the problems of localization encountered at the time of the modeling of the concrete without reinforcements. Obviously, a total model represents the local phenomena in a coarse way and requires more validation before its application to the industrial examples.

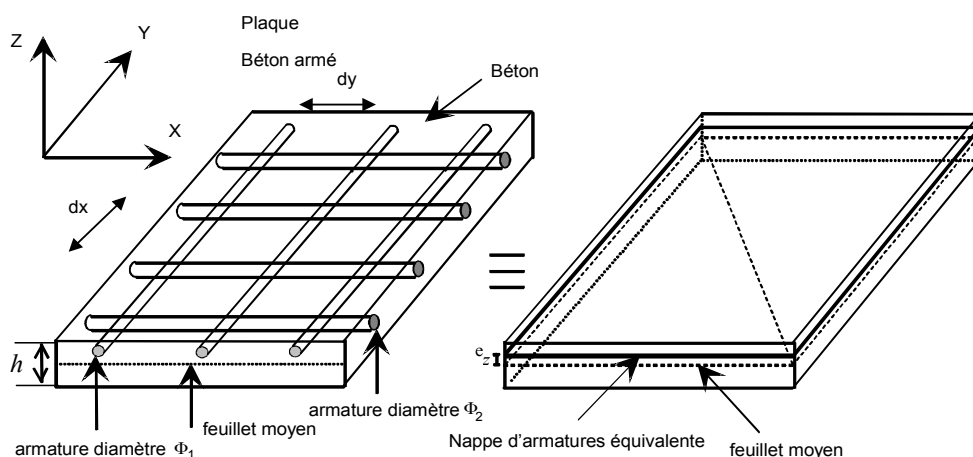

Figure 1.1-a : Reinforced concrete flagstone.

1.2 Objectives of the law GLRC_DM

The model `GLRC_DM` is able to represent the damage of a reinforced concrete plate, when this one remains limited, i.e. without reaching the rupture. It was inspired by the model `GLRC_DAMAGE` and is complementary for him. If `GLRC_DAMAGE` can as represent the damage, that is not possible as for the loading in inflection without any impact on the behavior out of membrane. On this point `GLRC_DM` is more faithful to physics, but contrary to `GLRC_DAMAGE` it does not make it possible to take into account plasticity. While being simpler, `GLRC_DM` is also more performing on the level of the cost of calculation and the digital robustness.

One aims at an identical behavior in the directions Ox and Oy ; more tablecloths of higher and lower reinforcement are supposed to be identical.

2 Formulation of the model of behavior

The use of the theory of the plates and thin hulls makes it possible to effectively describe the mechanical behavior of the reinforced concrete structures, which are generally slim.

In a first stage of the construction of the model, one supposes the existence of a medium homogenized with the same mechanical behavior as the reinforced concrete structure, in which one is interested. To simplify, the assumption is made that this medium is isotropic and that the element of structure studied is symmetrical compared to its average layer. These assumptions are not essential for the formulation, but were made to simplify the approach. Moreover, it is estimated that their impact on the behavior is less compared to the cracking, which is with area of interest model.

One must note that the use of this model is associated with that of an element of plate. It is usable only within the framework of finite elements **DKT** (supported modeling: **DKTG**), corresponding to the theory of **Coil-Kirchhoff**, where one neglects any transverse distortion in the thickness of the plate.

2.1 Free energy

For an isotropic homogeneous continuous medium with the linear elastic behavior one can write the voluminal density of the free energy like:

$$\Phi_e(\boldsymbol{\varepsilon}) = \frac{\lambda}{2} \text{tr}(\boldsymbol{\varepsilon})^2 + \mu \sum_{i=1}^3 \tilde{\varepsilon}_i^2$$

where λ, μ are the coefficients of Lamé, $\boldsymbol{\varepsilon}$ the tensor of deformation and $\tilde{\varepsilon}_i$ its eigenvalues. As for the model **ENDO_ISOT_BETON** one introduces the damage by a function $\xi(\cdot, d_i)$, d_i being a variable of damage. Therefore, for a endommageable medium, the free energy is written:

$$\Phi_{ed}(\boldsymbol{\varepsilon}, d_j) = \frac{\lambda}{2} \text{tr}(\boldsymbol{\varepsilon})^2 \xi(\text{tr}(\boldsymbol{\varepsilon}), d_j) + \mu \sum_{i=1}^3 \tilde{\varepsilon}_i^2 \xi(\tilde{\varepsilon}_i, d_j) \quad (2.1-1)$$

with the function $(x, d) \in \mathbb{R}^2 \rightarrow \xi(x, d) \leq 1$ checking a priori $\frac{\partial \xi}{\partial d} \leq 0$ to represent the loss of stiffness related to the damage, and $\frac{\partial \xi}{\partial x} = 0$ pour $x \in]-\infty, 0[\cup]0, +\infty[$, the jump in 0 allowing to represent the discontinuity of behaviour between traction and compression.

The equation [eq 2.1-1] is valid for a continuous medium and one will apply it to a plate of Coils-Kirchhoff $\omega \times \left] \frac{-h}{2}; \frac{h}{2} \right]$, thickness h (one notes $z = x_3$), where one has assumptions kinematics of Hencky-Mindlin (see [bib9]):

$$\begin{pmatrix} U_1(x_1, x_2, z) \\ U_2(x_1, x_2, z) \\ U_z(x_1, x_2, z) \end{pmatrix} = \underbrace{\begin{pmatrix} u_1(x_1, x_2) \\ u_2(x_1, x_2) \\ u_z(x_1, x_2) \end{pmatrix} + z \begin{pmatrix} \theta_2(x_1, x_2) \\ -\theta_1(x_1, x_2) \\ 0 \end{pmatrix}}_{\substack{\text{cinématique de plaque} \\ \mathbf{u}^s \in \mathbf{V}_s}} + \underbrace{\begin{pmatrix} u_1^c(x_1, x_2, z) \\ u_2^c(x_1, x_2, z) \\ u_z^c(x_1, x_2, z) \end{pmatrix}}_{\substack{\text{déplacement complémentaire} \\ \mathbf{u}^c \in \mathbf{V}_c}}$$

where $\mathbf{U} = (U_1 \ U_2 \ U_z)^T$ is the field of displacement in 3D, $\mathbf{u} = (u_1 \ u_2 \ u_z)^T$ the displacement of the average layer and θ_x, θ_y its rotations. Thus, the tensor of deformation, definite like:

$$\varepsilon_{ij} = \frac{1}{2} \left(\frac{\partial U_i}{\partial x_j} + \frac{\partial U_j}{\partial x_i} \right), \quad i, j = 1..3$$

is also written like:

$$\begin{aligned} \varepsilon_{11} &= \underbrace{\varepsilon_{11}}_{\varepsilon_{11}^s} + z \kappa_{11} + u_{1,1}^c \\ \varepsilon_{22} &= \underbrace{\varepsilon_{22}}_{\varepsilon_{22}^s} + z \kappa_{22} + u_{2,2}^c \\ \varepsilon_{12} &= \underbrace{\varepsilon_{12}}_{\varepsilon_{12}^s} + z \kappa_{12} + \frac{1}{2} (u_{2,1}^c + u_{1,2}^c) \\ \varepsilon_{1z} &= \varepsilon_{1z}^c = \frac{1}{2} u_{3,1}^c \\ \varepsilon_{2z} &= \varepsilon_{2z}^c = \frac{1}{2} u_{3,2}^c \\ \varepsilon_{zz} &= \varepsilon_{zz}^c = u_{3,z}^c \end{aligned} \tag{2.1-2}$$

where $\boldsymbol{\varepsilon}$ is the tensor of the extension will membranaire, defined in the plan:

$$\varepsilon_{ij} = \frac{1}{2} \left(\frac{\partial u_i}{\partial x_j} + \frac{\partial u_j}{\partial x_i} \right), \quad i, j = 1..2$$

and $\boldsymbol{\kappa}$ the tensor of variation of courbURE, defined in the plan:

$$\kappa_{11} = \frac{\partial \theta_2}{\partial x_1}, \quad \kappa_{22} = \frac{-\partial \theta_1}{\partial x_2}, \quad \kappa_{12} = \frac{1}{2} \left(\frac{\partial \theta_2}{\partial x_2} - \frac{\partial \theta_1}{\partial x_1} \right)$$

relations to which the assumption of plane constraints is added $\sigma_{zz} = 0, \sigma_{1z} = 0, \sigma_{2z} = 0$ who will determine the complementary field of displacement $\mathbf{u}^c \in \mathbf{V}_c$. In the theory used here, only two components of rotation are introduced θ_x and θ_y , which implies that the tensor of variation of curve is 2D and has only 3 independent components.

By introducing these assumptions kinematics, cf [éq. 2.1-2], in the expression of the free energy, [éq. 2.1-1], one can determine the eigenvalues of the deformation $\tilde{\varepsilon}_i = (\boldsymbol{\varepsilon} + z \boldsymbol{\kappa})_i$. These eigenvalues being, in general, of the nonpolynomial functions of the coordinate z , the integral $\int \phi_{ed} dz$ is not calculable analytically. This formulation would thus not be adapted for the application to the elements of structure.

Instead of the formulation [éq. 2.1-1], one will rather use a formulation of the directly definite free energy in generalized deformations, $\boldsymbol{\varepsilon}$ and $\boldsymbol{\kappa}$:

$$\begin{aligned} \Phi_{ed}(\boldsymbol{\epsilon}, \boldsymbol{\kappa}, \varepsilon_{zz}, d_j) &= \frac{\lambda}{2} (\text{tr}(\boldsymbol{\epsilon}) + \varepsilon_{zz})^2 \cdot \xi_m(\text{tr}(\boldsymbol{\epsilon}), d_j) + \mu \left(\sum_{i=1}^2 \tilde{\epsilon}_i^2 \cdot \xi_m(\tilde{\epsilon}_i, d_j) + \varepsilon_{zz}^2 \right) \\ &+ \frac{\lambda}{2} z^2 \text{tr}(\boldsymbol{\kappa})^2 \cdot \xi_f(\text{tr}(\boldsymbol{\kappa}), d_j) + \mu z^2 \sum_{i=1}^2 \tilde{\kappa}_i^2 \cdot \xi_f(\tilde{\kappa}_i, d_j) + z(\cdot) \end{aligned} \quad (2.1-3)$$

where $z(\cdot)$ contains all the terms coupling $\boldsymbol{\epsilon}$ and $\boldsymbol{\kappa}$, which disappears after integration on z , if the assumption is made that the plate/beam is symmetrical compared to the average layer. One thus obtains the surface density of the free energy:

$$\begin{aligned} \Phi_{ed}^S(\boldsymbol{\epsilon}, \boldsymbol{\kappa}, \varepsilon_{zz}, d_j) &= \int_{-\frac{h}{2}}^{\frac{h}{2}} \Phi_{ed}(\boldsymbol{\epsilon}, \boldsymbol{\kappa}, \varepsilon_{zz}, d_j) dz \\ &= \frac{\lambda_m}{2} (\text{tr}(\boldsymbol{\epsilon}) + \varepsilon_{zz})^2 \cdot \xi_m(\text{tr}(\boldsymbol{\epsilon}), d_j) + \mu_m \left(\sum_{i=1}^2 \tilde{\epsilon}_i^2 \cdot \xi_m(\tilde{\epsilon}_i, d_j) + \varepsilon_{zz}^2 \right) \\ &+ \frac{\lambda_f}{2} \text{tr}(\boldsymbol{\kappa})^2 \cdot \xi_f(\text{tr}(\boldsymbol{\kappa}), d_j) + \mu_f \sum_{i=1}^2 \tilde{\kappa}_i^2 \cdot \xi_f(\tilde{\kappa}_i, d_j) \end{aligned} \quad (2.1-4)$$

where h is the thickness of the plate and $\lambda_m, \lambda_f, \mu_m, \mu_f$ are defined with the section § 3.2. The surface density of the free energy is strictly convex for $d_j = 0$ (having correctly chosen the elastic coefficients).

In [éq 2.1-3] and [éq 2.1-4] we also made the assumption that the damage is not affected by the extension in z , which results in the absence of ε_{zz} arguments of the indicator of damage ξ_m . That is justified by the objective of this model which is to represent cracking perpendicular compared to the average layer, which starts either in membrane request or in inflection, but never in extension by ε_{zz} . Moreover, from the digital point of view of resolution approached low, this assumption facilitates the local calculation of the variables of damage d_j and the satisfaction of the assumption of plane constraint $\sigma_{zz} = 0$.

Note:

*In [éq. 2.1-4], it is observed that the deformation ε_{zz} is introduced explicitly only on the membrane term of energy. The effect of plane constraints on the membrane behavior will be thus affected by the damage. This is not the case in inflection. One could imagine that the condition of plane constraints is written by integrating a coupling inflection-membrane, itself depend on the damage, but that was not fall here.
Section § will be seen 3.2 how to determine the parameters of the model starting from its answers on simple cases.*

As for the variable of damage, it is described by two components, one of both representative overall the damage on the side of the higher face of the plate and the other representing the damage on the side of the lower face of the plate:

$$d(z) = \begin{cases} d_1 & \text{si } z \geq 0 \\ d_2 & \text{si } z < 0 \end{cases}$$

It remains to define the functions characteristic of the damage $\xi_m(\cdot, d_j)$ and $\xi_f(\cdot, d_j)$, so that the formulation, [éq 2.1-4], that is to say complete:

$$\xi_m(x, d_1, d_2) = \frac{1}{2} \left(\left(\frac{1 + \gamma_{mt} d_1}{1 + d_1} + \frac{1 + \gamma_{mt} d_2}{1 + d_2} \right) H(x) + \left(\frac{\alpha_c + \gamma_{mc} d_1}{\alpha_c + d_1} + \frac{\alpha_c + \gamma_{mc} d_2}{\alpha_c + d_2} \right) H(-x) \right) \in [0, 1]$$

and

$$\xi_f(x, d_1, d_2) = \frac{\alpha + \gamma_f d_1}{\alpha + d_1} H(x) + \frac{\alpha + \gamma_f d_2}{\alpha + d_2} H(-x) \in [0, 1]$$

where $H(\cdot)$ is the function of Heaviside.

Functions $(x, d) \in \mathbb{R}^2 \rightarrow \xi(x, d) \leq 1$, which is expressed same manner as that selected in law ENDO_ISOT_BETON, cf. [R7.01.04], by operating a change of variable on d_i , offer the advantage of giving a constant slope in the phases of damage. They are decreasing $\frac{\partial \xi}{\partial d} \leq 0$ and convex to represent the loss of stiffness related to the damage, and $\frac{\partial \xi}{\partial x} = 0$ pour $x \in]-\infty, 0[\cup]0, +\infty[$, the jump in 0 allowing to represent the behavioral change between traction and compression, however without introducing discontinuity. Variables of damage d_i grow until $+\infty$.

Functions characteristic of the damage $\xi_m(\cdot, d_j)$ and $\xi_f(\cdot, d_j)$ vary 1 with respectively γ_{mt} or γ_{mc} , and γ_f , for $d_j \rightarrow +\infty$. This model thus describes a damage partial but not total of material.

Parameters of damage γ_{mt} for traction out of membrane, γ_{mc} for compression out of membrane and γ_f for the inflection, can have values in $[0, 1]$, so that the model is not lenitive, which would involve difficulties of dependence to the space discretization and convergence. One will choose $\gamma_f \approx 0$ when the phenomenon corresponding has more impact on the damage and $\gamma_f \approx 1$ when this one is negligible. Thus, for the reinforced concrete, one expects $\gamma_{mc} \approx 1$ and $\gamma_{mt} \approx 0$. As for the parameter, α it makes it possible to adjust the contribution of the inflection the threshold of damage. The parameter α_c allows to modulate the evolution of the damage in compression.

2.2 Generalized constraints

According to the usual procedure one defines the constraints generalized (normal efforts and moments) by the derivative of the density of free energy compared to the generalized deformations, $\boldsymbol{\epsilon}$ and $\boldsymbol{\kappa}$:

$$\mathbf{N} = \frac{\partial \Phi_{ed}^S}{\partial \boldsymbol{\epsilon}} ; \quad \mathbf{M} = \frac{\partial \Phi_{ed}^S}{\partial \boldsymbol{\kappa}}$$

In our application, the generalized constraints are calculated in the reference mark of the clean vectors of the generalized deformations and they are written like (see calculation in appendix):

$$\begin{aligned} \tilde{N}_i &= \frac{\partial \Phi_{ed}^S}{\partial \tilde{\epsilon}_i} = \lambda_m (\text{tr}(\boldsymbol{\epsilon}) + \epsilon_{zz}) \cdot \xi_m(\text{tr}(\boldsymbol{\epsilon}), d_j) + 2\mu_m \tilde{\epsilon}_i \cdot \xi_m(\tilde{\epsilon}_i, d_j), \quad i=1..2 \\ \tilde{M}_i &= \frac{\partial \Phi_{ed}^S}{\partial \tilde{\kappa}_i} = \lambda_f \text{tr}(\boldsymbol{\kappa}) \cdot \xi_f(\text{tr}(\boldsymbol{\kappa}), d_j) + 2\mu_f \tilde{\kappa}_i \cdot \xi_f(\tilde{\kappa}_i, d_j), \quad i=1,2 \end{aligned} \quad (2.2-1)$$

It is easy to check (see appendix) that generalized constraints \mathbf{N} and \mathbf{M} , definite starting from the expressions [éq 2.2-1], the same clean vectors divide respectively as the generalized deformations $\boldsymbol{\epsilon}$ and $\boldsymbol{\kappa}$. If these clean vectors are indicated respectively like \mathbf{Q}_m and \mathbf{Q}_f , one can write:

$$\begin{aligned} \mathbf{N} &= \mathbf{Q}_m \tilde{\mathbf{N}} \mathbf{Q}_m^T \\ \text{and} \\ \mathbf{M} &= \mathbf{Q}_f \tilde{\mathbf{M}} \mathbf{Q}_f^T \end{aligned} \quad (2.2-2)$$

where $\tilde{\mathbf{N}}$ and $\tilde{\mathbf{M}}$ are the diagonal matrices made up of the eigenvalues defined in [éq 2.2-1]. It is important to note that the clean vectors for the part of membrane \mathbf{Q}_m and of inflection and \mathbf{Q}_f are completely independent.

In the same way, one defines the constraints of pinching like the dual variable of ϵ_{zz} :

$$\sigma_{zz} = \frac{\partial \Phi_{ed}^S}{\partial \epsilon_{zz}} = \lambda_m \xi_m(\text{tr}(\boldsymbol{\epsilon}), d_1, d_2) \cdot (\text{tr}(\boldsymbol{\epsilon}) + \epsilon_{zz}) + 2\mu_m \epsilon_{zz} \quad (2.2-3)$$

which one will impose the condition of plane constraints: $\sigma_{zz} = 0$.

2.3 Thresholds and evolution of the damage

To be able to define a threshold of damage within the framework of the assumption of one *generalized standard material* (see [feeding-bottle 1], [feeding-bottle 7]), one introduces the thermodynamic forces associated with the variables d_1 and d_2 :

$$Y_j = - \frac{\partial \Phi_{ed}^S}{\partial d_j} = Y_j^m + Y_j^f \quad (2.3-1)$$

where

$$Y_j^m(\epsilon, d_j, \epsilon_{zz}) = \frac{1}{(1+d_j)^2} \left(\frac{\lambda_m}{4} (\text{tr}(\epsilon) + \epsilon_{zz})^2 \cdot G_m(\text{tr}(\epsilon), d_j) + \frac{\mu_m}{2} \left(\sum_{i=1}^2 \tilde{\epsilon}_i^2 \cdot G_m(\tilde{\epsilon}_i, d_j) \right) \right)$$

while noting

$$G_m(x, d_j) = (1 - \gamma_{mt}) H(x) + \left(\frac{\alpha_c (1 - \gamma_{mc}) (1 + d_j)^2}{(\alpha_c + d_j)^2} \right) H(-x) \quad \in [0, 1]$$

so that:
$$\frac{\partial \xi_m(x, d_1, d_2)}{\partial d_j} = - \frac{G_m(x, d_j)}{2(1+d_j)^2}, \quad (2.3-2)$$

and

$$Y_j^f(\kappa, d_j) = \frac{\alpha}{(\alpha + d_j)^2} Y_j^{f,0}(\kappa)$$

with

$$Y_j^{f,0}(\kappa) = (1 - \gamma_f) \left(\frac{\lambda_f}{2} \text{tr}(\kappa)^2 H((-1)^{(j+1)} \cdot \text{tr}(\kappa)) + \mu_f \sum_{i=1}^2 \tilde{\kappa}_i^2 H((-1)^{(j+1)} \cdot \tilde{\kappa}_i) \right)$$

The thresholds of damage are defined by:

$$f_{d_j} = Y_j(\epsilon, \kappa, d_j, \epsilon_{zz}) - k_{0_j} \leq 0 \quad (2.3-3)$$

where k_{0_j} are constants of threshold. These thresholds define the convex field of reversibility within the space of (ϵ, κ) .

In theory constants of threshold k_{0_1} and k_{0_2} could be different, but according to the assumption that one makes on the symmetry of the plate compared to the average layer, the two values are the same ones: $k_{0_1} = k_{0_2} = k_0$.

One sees in [éq 2.3-2] that the parameter α babbt metal the contribution of the inflection to the threshold of initial damage, since:

$$f_{d_j}(d_j=0) = Y_j^m(\epsilon, d_j=0) + \frac{1}{\alpha} Y_j^{f,0}(\kappa) - k_0$$

The law of evolution of the variables of damage d_1 and d_2 is defined by the rule of normality in the thresholds [éq 2.3-3], for which one can define the pseudopotential of dissipation $D(\delta)$:

$$\begin{aligned} \dot{d}_j &= \eta \frac{\partial f_{d_j}}{\partial Y_j}, \quad \text{avec } \eta \geq 0 \\ \Leftrightarrow Y_j &\in \partial D(\dot{d}_j) \Leftrightarrow D(\dot{d}_j) - D(\delta) \geq Y_j(\dot{d}_j - \delta), \quad \forall \delta \geq 0 \end{aligned} \quad (2.3-4)$$

Values of damage d_1 and d_2 are determined perfectly by the following conditions:

$$\begin{aligned} & \text{if } f_{d_j} < 0 \text{ then } \dot{d}_j = 0 \\ \text{if } f_{d_j} = 0 \text{ then } & \begin{cases} \dot{d}_j \geq 0, \\ \dot{f}_{d_j} = 0, \text{ condition de cohérence} \\ \dot{d}_j f_{d_j} = 0, \text{ condition de complémentarité (Kühn-Tucker)} \end{cases} \end{aligned} \quad (2.3-5)$$

The evolution of the variables of damage is thus obtained using the condition of coherence, functions $\xi(x, d)$ being convex, modules of work hardening $-f_{,d_j}$ are positive (the coefficients checking $\gamma \in [0, 1]$):

$$\dot{d}_j = -\frac{[f_{,Y} \cdot Y_{, \epsilon} \cdot \dot{\epsilon}]_+}{f_{,d_j}} \quad (2.3-6)$$

One notes that in pure membrane load uniaxiale endommageante ($\dot{d}_1 = \dot{d}_2 \geq 0$), the thermodynamic force is expressed: $Y^m(d) = -E_{eq}^m h \frac{\epsilon^2 \cdot \xi_{m,d}(d)}{2}$, $E_{eq}^m h$ being uniaxial membrane elastic stiffness. Lcondition of coherence has is written then :

$$f_{,d} = E_{eq}^m h \left(-\epsilon \dot{\epsilon} \xi_{m,d} - \frac{\epsilon^2 \dot{d} \xi_{m,dd}}{2} \right) = 0 \quad (2.3-7)$$

From where: $\dot{d}_m = -\frac{2 \dot{\epsilon} \xi_{m,d}}{\epsilon \xi_{m,dd}}$ and thus the law of damaging uniaxial pure load membrane is:

$$\dot{N} = E_{eq}^m h \left(\xi_{m,d} \dot{d} \epsilon + \xi_m \dot{\epsilon} \right) = E_{eq}^m h \dot{\epsilon} \left(\xi_m - 2 \frac{\xi_{m,d}^2}{\xi_{m,dd}} \right) = \gamma_m E_{eq}^m h \dot{\epsilon} \quad (2.3-8)$$

what makes it possible to interpret the role of the parameter γ_m : the slope being constant, which is the justification of the algebraic form of the function ξ_m .

2.4 Digital integration

Contrary in the majority of the nonlinear unelastic laws of behavior, that presented here does not require the discretization of the equations of evolution of the internal variables. One adopts a method of direct discretization implicit in time.

Variables d_j can be calculated directly starting from the condition of coherence, [éq 2.3-4]. The only time where one refers to the "speed of damage" is to check that it is positive $\dot{d}_j \geq 0$. For an incremental calculation this condition results in $d_j^n \geq d_j^{n-1}$ with the step of time $n > 1$, therefore without reference to a particular diagram of temporal integration.

Let us place at a given moment t_n way of loading. One carries out initially an elastic stage of prediction (tensor of elasticity evaluated with the variables of damage d_j^{n-1} solidified at the preceding stage), from where $(\boldsymbol{\epsilon}^n, \boldsymbol{\kappa}^n)$. One calculates then new ε_{zz}^{n0} :

$$\sigma_{zz}^n = 0 \Rightarrow \varepsilon_{zz}^{n0}(\boldsymbol{\epsilon}^n, d_1^{n-1}, d_2^{n-1}) = - \frac{\lambda_m \xi_m(\text{tr}(\boldsymbol{\epsilon}^n), d_1^{n-1}, d_2^{n-1})}{2\mu_m + \lambda_m \xi_m(\text{tr}(\boldsymbol{\epsilon}^n), d_1^{n-1}, d_2^{n-1})} \text{tr}(\boldsymbol{\epsilon}^n)$$

to see [éq 2.2-3].

One calculates then $f_{d_j}^{n0}(\boldsymbol{\epsilon}^n, \boldsymbol{\kappa}^n, d_j^{n-1}, \varepsilon_{zz}^{n0})$ to check the thresholds of damage. If $f_{d_j}^{n0} \leq 0$, the damage does not evolve: $d_j^n = d_j^{n-1}$ and $\varepsilon_{zz}^n = \varepsilon_{zz}^{n0}$, and the generalized constraints are calculated according to [éq 2.2-1].

When $f_{d_j}^{n0} > 0$, the damage can evolve and one must solve the equations:

$$f_{d_j}^n = Y_j(\boldsymbol{\epsilon}^n, \boldsymbol{\kappa}^n, d_j^n, \varepsilon_{zz}^n) - k_0 = 0$$

What corresponds to the resolution of the nonlinear equations, with $\boldsymbol{\epsilon}, \boldsymbol{\kappa}$ given:

$$R_{d_j}(d_j, \boldsymbol{\epsilon}, \boldsymbol{\kappa}, \varepsilon_{zz}) = \frac{1}{(1+d_j)^2} \left(\frac{\lambda_m}{4} (\text{tr}(\boldsymbol{\epsilon}) + \varepsilon_{zz})^2 \cdot G_m(\text{tr}(\boldsymbol{\epsilon}), d_j) + \frac{\mu_m}{2} \left(\sum_{i=1}^2 \tilde{\varepsilon}_i^2 G_m(\tilde{\varepsilon}_i, d_j) \right) \right) - k_0$$

$$\frac{\alpha(1-\gamma_f)}{(\alpha+d_j)^2} \left(\frac{\lambda_f}{2} \text{tr}(\boldsymbol{\kappa})^2 H((-1)^{(j+1)} \text{tr}(\boldsymbol{\kappa})) + \mu_f \sum_{i=1}^2 \tilde{\kappa}_i H((-1)^{(j+1)} \tilde{\kappa}_i) \right) - k_0 \quad (2.4-1)$$

The equation [éq 2.4-1] must be solved by taking into account also the condition of plane constraint, which makes it possible to express $\varepsilon_{zz}(\boldsymbol{\epsilon}, d_j)$, cf [éq 2.2-3]:

$$\sigma_{zz} = 0 \Rightarrow \varepsilon_{zz}(\boldsymbol{\epsilon}, d_1, d_2) = - \frac{\lambda_m \xi_m(\text{tr}(\boldsymbol{\epsilon}), d_1, d_2)}{2\mu_m + \lambda_m \xi_m(\text{tr}(\boldsymbol{\epsilon}), d_1, d_2)} \text{tr}(\boldsymbol{\epsilon}) \quad (2.4-2)$$

One solves the equations [éq 2.4-1] and [éq 2.4-2] by the method of Newton. One starts with a phase of prediction, of type explicit Euler:

$$d_j^{n(0)} = d_j^{n-1} + \left(\frac{dR_{d_j}}{d(d_j)} \right) \Big|_{d_j^{n-1}}^{-1} \cdot (k_0 - Y_j(\boldsymbol{\epsilon}^n, \boldsymbol{\kappa}^n, d_j^{n-1}, \varepsilon_{zz}^{n0}))$$

Then one treats the phase of correction, with the iteration $(m) > 1$:

1. $\Delta d_j^{n(m)} = \left(\frac{dR_{d_j}}{d(d_j)} \right) \Big|_{d_j^{n(m-1)}}^{-1} \cdot (k_0 - Y_j(\boldsymbol{\epsilon}^n, \boldsymbol{\kappa}^n, d_j^{n(m-1)}, \varepsilon_{zz}^{n(m-1)}))$
2. $d_j^{n(m)} = d_j^{n(m-1)} + \Delta d_j^{n(m)}$
3. $\varepsilon_{zz}^{n(m)} = \varepsilon_{zz}(\boldsymbol{\epsilon}^n, d_1^{n(m)}, d_2^{n(m)})$

This phase of correction is completed when the convergence criteria expressed in energy term are reached:

$$\Delta d_j^{n(m)} \cdot R_{d_j}^{n(m)} < \eta_{tolerance} \cdot k_0$$

The tangent operator of this nonlinear system is defined like:

$$\begin{aligned} \frac{dR_{d_j}}{d(d_j)} &= \frac{\partial R_{d_j}}{\partial \varepsilon_{zz}} \frac{\partial \varepsilon_{zz}}{\partial d_j} + \frac{\partial R_{d_j}}{\partial d_j} \\ &= \frac{1}{(1+d_j)^2} \left(\frac{\lambda_m}{2} (\text{tr}(\boldsymbol{\epsilon}) + \varepsilon_{zz}) G_m(\text{tr}(\boldsymbol{\epsilon}), d_j) \frac{\partial \varepsilon_{zz}}{\partial d_j} \right) \\ &+ \frac{1}{(1+d_j)^2} \left(\frac{\lambda_m}{4} (\text{tr}(\boldsymbol{\epsilon}) + \varepsilon_{zz})^2 \frac{\partial G_m(\text{tr}(\boldsymbol{\epsilon}), d_j)}{\partial d_j} \varepsilon_{zz} + \frac{\mu_m}{2} \left(\sum_{i=1}^2 \tilde{\epsilon}_i^2 \frac{\partial G_m(\tilde{\epsilon}_i, d_j)}{\partial d_j} \right) \right) \\ &- \frac{2}{(1+d_j)^3} \left(\frac{\lambda_m}{4} (\text{tr}(\boldsymbol{\epsilon}) + \varepsilon_{zz})^2 G_m(\text{tr}(\boldsymbol{\epsilon}), d_j) + \frac{\mu_m}{2} \left(\sum_{i=1}^2 \tilde{\epsilon}_i^2 G_m(\tilde{\epsilon}_i, d_j) \right) \right) \\ &- \frac{2\alpha(1-\gamma_f)}{(\alpha+d_j)^3} \left(\frac{\lambda_f}{2} \text{tr}(\boldsymbol{\kappa})^2 H((-1)^{(j+1)} \text{tr}(\boldsymbol{\kappa})) + \mu_f \sum_{i=1}^2 \tilde{\kappa}_i^2 H((-1)^{(j+1)} \tilde{\kappa}_i) \right) \end{aligned} \quad (2.4-3)$$

where:

$$\frac{\partial \varepsilon_{zz}}{\partial d_j} = - \frac{\lambda_m (\text{tr}(\boldsymbol{\epsilon}) + \varepsilon_{zz})}{(2\mu_m + \lambda_m \xi_m(\text{tr}(\boldsymbol{\epsilon}), d_j))} \frac{\partial \xi_m(\text{tr}(\boldsymbol{\epsilon}), d_j)}{\partial d_j} \quad (2.4-4)$$

and:

$$\frac{\partial \xi_m(x, d_j)}{\partial d_j} = - \frac{1}{2} \left(\frac{1-\gamma_{mt}}{(1+d_j)^2} H(x) + \frac{\alpha_c(1-\gamma_{mc})}{(\alpha_c+d_j)^2} H(-x) \right) = - \frac{G_m(x, d_j)}{2(1+d_j)^2} \quad (2.4-5)$$

It is checked that one has well $\frac{\partial \xi_m}{\partial d_j}(x, d_1, d_2) < 0$ as expected.

2.5 Operator of tangent stiffness

As the main aim of a total model is to propose an approach simplified with the modeling of a complex material, such as the reinforced concrete, it is essential that its digital performance is optimal. Thus, to return the model adapted to calculations with implicit schemes in time, either into quasi-static or in transitory dynamics, the calculation of the coherent tangent stiffness becomes essential to have a quadratic and robust convergence total iterative process of Newton.

The essence of the calculation of the model is carried out in the reference mark of the clean vectors of the tensors of deformations generalized (and of the generalized constraints, cf [éq 2.2-2]), tangent stiffness being thus also expressed in the same reference mark. The transformation necessary to then be able to use it in the assembly of the matrix of total stiffness is specified in the following chapter.

In order to simplify the writing one defines a vector of generalized constraints (membrane effort, bending moment), Σ , and a vector of generalized deformations (extension, curve), E , like:

$$\Sigma = (\tilde{N}_1 \quad \tilde{N}_2 \quad \tilde{M}_1 \quad \tilde{M}_2)^T$$

$$E = (\tilde{\epsilon}_1 \quad \tilde{\epsilon}_2 \quad \tilde{\kappa}_1 \quad \tilde{\kappa}_2)^T$$

The operator of tangent stiffness C is defined by the relation in real evolution:

$$d\Sigma = C \cdot dE$$

It can be calculated as the sum of two contributions, that which corresponds to an not-evolution of the damage and that which is due to the evolution of the damage. These contributions can be named: contribution *rubber band* and contribution *dissipative* :

$$C = \underbrace{\frac{d\Sigma}{dE} \Big|_{\dot{d}_j=0}}_{C_e} + \underbrace{\frac{d\Sigma}{dE} \Big|_{f_{d_j}=0}}_{C_d} \quad (2.5-1)$$

Moreover, one takes account of the structure of the tensor C composed of the contributions effort normal-extension, moment-curve and their couplings. More particularly tensors C_e and C_d are following form:

$$C_e = \begin{pmatrix} C_e^{mm} & \mathbf{0} \\ \mathbf{0} & C_e^{ff} \end{pmatrix}; \quad C_d = \begin{pmatrix} C_d^{mm} & C_d^{mf} \\ (C_d^{mf})^T & C_d^{ff} \end{pmatrix} \quad (2.5-2)$$

One sees [éq 2.5-2] that the coupling moments/extension and efforts of membrane/curve are introduced only through the dissipative part. This coupling has a physical justification, since any cracking perpendicular to the average layer of the plate affects as well the behavior out of membrane as in inflection.

Submatrices C_e^{mm} , C_e^{ff} , C_d^{mm} , C_d^{mf} , C_d^{ff} are given in the clean reference mark by the expressions which follow:

$$(C_e^{mm})_{ij} = \frac{\partial \tilde{N}_i}{\partial \tilde{\epsilon}_j} \Big|_{\dot{d}_k=0} = \frac{2\lambda_m \xi_m(\text{tr}(\epsilon), d_k)}{2\mu_m + \lambda_m \xi_m(\text{tr}(\epsilon), d_k)} + 2\mu_m \xi_m(\tilde{\epsilon}_j, d_k) \delta_{ij}$$

$$(C_e^{ff})_{ij} = \frac{\partial \tilde{M}_i}{\partial \tilde{\kappa}_j} \Big|_{\dot{d}_k=0} = \lambda_f \xi_f(\text{tr}(\kappa), d_k) + 2\mu_f \xi_f(\tilde{\kappa}_j, d_k) \delta_{ij} \quad (2.5-3)$$

$$\begin{aligned}
 (\mathbf{C}_d^{mm})_{ij} &= \frac{\partial \tilde{N}_i}{\partial \tilde{\epsilon}_j} \Big|_{f_{d_k}=0} = \frac{\partial \tilde{N}_i}{\partial d_k} \cdot \frac{d(d_k)}{d \tilde{\epsilon}_j} \Big|_{f_{d_k}=0} \quad (\text{summation on } k) \\
 (\mathbf{C}_d^{ff})_{ij} &= \frac{\partial \tilde{M}_i}{\partial \tilde{\kappa}_j} \Big|_{f_{d_k}=0} = \frac{\partial \tilde{M}_i}{\partial d_k} \cdot \frac{d(d_k)}{\partial \tilde{\kappa}_j} \Big|_{f_{d_k}=0} \quad (\text{summation on } k) \\
 (\mathbf{C}_d^{mf})_{ij} &= \frac{\partial \tilde{N}_i}{\partial \tilde{\kappa}_j} \Big|_{f_{d_k}=0} = \frac{\partial \tilde{N}_i}{\partial d_k} \cdot \frac{d(d_k)}{\partial \tilde{\kappa}_j} \Big|_{f_{d_k}=0} \quad (\text{summation on } k)
 \end{aligned} \tag{2.5-4}$$

where

$$\begin{aligned}
 \frac{\partial \tilde{N}_i}{\partial d_k} &= \lambda_m (\text{tr}(\boldsymbol{\epsilon}) + \epsilon_{zz}) \frac{\partial \xi_m(\text{tr}(\boldsymbol{\epsilon}), d_j)}{\partial d_k} + \lambda_m \xi_m(\text{tr}(\boldsymbol{\epsilon}), d_j) \frac{\partial \epsilon_{zz}}{\partial d_k} + 2\mu_m \tilde{\epsilon}_i \frac{\partial \xi_m(\tilde{\epsilon}_i, d_j)}{\partial d_k} \\
 \text{and } \frac{\partial \tilde{M}_i}{\partial d_k} &= \lambda_f \text{tr}(\boldsymbol{\kappa}) \frac{\partial \xi_f(\text{tr}(\boldsymbol{\kappa}), d_1, d_2)}{\partial d_k} + 2\mu_f \tilde{\kappa}_i \frac{\partial \xi_f(\tilde{\kappa}_i, d_1, d_2)}{\partial d_k}
 \end{aligned} \tag{2.5-5}$$

with

$$\frac{\partial \xi_f}{\partial d_k}(x, d_1, d_2) = -\alpha \frac{(1-\gamma_f)}{(\alpha + d_k)^2} H((-1)^{(k+1)}x)$$

Besides the expressions [éq 2.5-5], one resorts to the equations [éq 2.4-5] to determine

$$\frac{\partial \xi_m}{\partial d_k}(x, d_1, d_2) .$$

The derivative $\frac{d(d_k)}{d \tilde{\epsilon}_i} \Big|_{f_{d_k}=0}$ and $\frac{d(d_k)}{d \tilde{\kappa}_i} \Big|_{f_{d_k}=0}$ are calculated by differentiating the equation

$R_{d_k} = 0$ respectively compared to d_k , $\tilde{\epsilon}_i$ and $\tilde{\kappa}_i$, (see [éq. 2.4-1]). When the two damage mechanisms are activated, one is brought to solve the systems which follow:

$$\begin{pmatrix} A_{11} & A_{12} \\ A_{21} & A_{22} \end{pmatrix} \begin{pmatrix} \frac{d(d_1)}{d \tilde{\epsilon}_i} \\ \frac{d(d_2)}{d \tilde{\epsilon}_i} \end{pmatrix} = \begin{pmatrix} B_1^m \\ B_2^m \end{pmatrix} \quad \text{and} \quad \begin{pmatrix} A_{11} & A_{12} \\ A_{21} & A_{22} \end{pmatrix} \begin{pmatrix} \frac{d(d_1)}{d \tilde{\kappa}_i} \\ \frac{d(d_2)}{d \tilde{\kappa}_i} \end{pmatrix} = \begin{pmatrix} B_1^f \\ B_2^f \end{pmatrix} \tag{2.5-6}$$

$$\text{with } A_{jk} = \frac{\partial Y_j}{\partial d_k}, \quad B_k^m = \frac{-\partial Y_k}{\partial \boldsymbol{\epsilon}} = \frac{\partial \tilde{N}}{\partial d_k}, \quad B_k^f = \frac{-\partial Y_k}{\partial \boldsymbol{\kappa}} = \frac{\partial \tilde{M}}{\partial d_k};$$

thus:

$$\frac{d(d_1)}{d \tilde{\epsilon}_i} = \frac{A_{22} B_1^m - A_{12} B_2^m}{A_{22} A_{11} - A_{12} A_{21}} \quad \text{and} \quad \frac{d(d_2)}{d \tilde{\epsilon}_i} = \frac{A_{11} B_2^m - A_{21} B_1^m}{A_{11} A_{22} - A_{21} A_{12}}$$

$$\frac{d(d_1)}{d\tilde{\kappa}_i} = \frac{A_{22}B_1^f - A_{12}B_2^f}{A_{22}A_{11} - A_{12}A_{21}} \quad \text{and} \quad \frac{d(d_2)}{d\tilde{\kappa}_i} = \frac{A_{11}B_2^f - A_{21}B_1^f}{A_{11}A_{22} - A_{21}A_{12}}$$

where:

$$\begin{aligned} A_{jk} = & \frac{1}{(1+d_j)^2} \left(\frac{\lambda_m}{2} (\text{tr}(\boldsymbol{\epsilon}) + \varepsilon_{zz}) \frac{\partial \varepsilon_{zz}}{\partial d_k} G_m(\text{tr}(\boldsymbol{\epsilon}), d_j) \right) \\ & + \left(\frac{1}{(1+d_j)^2} \left(\frac{\lambda_m}{4} (\text{tr}(\boldsymbol{\epsilon}) + \varepsilon_{zz})^2 \frac{\partial G_m(\text{tr}(\boldsymbol{\epsilon}), d_j)}{\partial d_k} + \frac{\mu_m}{2} \sum_{i=1}^2 \tilde{\epsilon}_i^2 \frac{\partial G_m(\tilde{\epsilon}_i, d_j)}{\partial d_k} \right) \right. \\ & - \frac{2}{(1+d_j)^3} \left(\frac{\lambda_m}{4} (\text{tr}(\boldsymbol{\epsilon}) + \varepsilon_{zz})^2 G_m(\text{tr}(\boldsymbol{\epsilon}), d_j) + \frac{\mu_m}{2} \sum_{i=1}^2 \tilde{\epsilon}_i^2 G_m(\tilde{\epsilon}_i, d_j) \right) \\ & \left. - \frac{2\alpha(1-\gamma_f)}{(\alpha+d_j)^3} \left(\frac{\lambda_f}{2} \text{tr}(\boldsymbol{\kappa})^2 H((-1)^{(j+1)} \text{tr}(\boldsymbol{\kappa})) + \mu_f \sum_{i=1}^2 \tilde{\kappa}_i^2 H((-1)^{(j+1)} \tilde{\kappa}_i) \right) \right) \delta_{jk} \end{aligned} \quad (2.5-7)$$

with:

$$\frac{\partial G_m(x, d_j)}{\partial d_k} = \left(\frac{2\alpha_c(1+\gamma_{mc})(1+d_j)(\alpha_c-1)}{(\alpha_c+d_j)^3} \right) H(-x) \quad (2.5-8)$$

and $\frac{\partial \varepsilon_{zz}}{\partial d_k}$ given by [éq. 2.4-1]. The matrix (A_{jk}) is quite invertible, cf section § 2.4.

2.6 Change of reference mark

The approach of change of reference mark is identical to that developed for the model ENDO_ISOT_BETON (see section [2.4.4.1] [R7.01.04]) with the only difference which it applies to the generalized constraints and deformations. We obtain the components thus of:

$$\mathbf{C} = \begin{pmatrix} \mathbf{C}^{mm} & \mathbf{C}^{mf} \\ (\mathbf{C}^{mf})^T & \mathbf{C}^{ff} \end{pmatrix}$$

as being:

$$\begin{aligned} (\mathbf{C}^{mm})_{ijkl} &= \frac{\partial N_{ij}}{\partial \epsilon_{kl}} = \sum_{m,n} Q_{im}^m Q_{jm}^m Q_{kn}^m Q_{ln}^m \cdot \frac{\partial \tilde{N}_m}{\partial \tilde{\epsilon}_n} \\ &+ \frac{1}{2} \sum_{\substack{m,n \\ m \neq n}} \left(\frac{(Q_{km}^m Q_{ln}^m + Q_{lm}^m Q_{kn}^m)(Q_{in}^m Q_{jm}^m + Q_{jn}^m Q_{im}^m)}{\tilde{\epsilon}_n - \tilde{\epsilon}_m} \right) \tilde{N}_m \end{aligned}$$

$$\begin{aligned}
 (\mathbf{C}^{ff})_{ijkl} &= \frac{\partial M_{ij}}{\partial \kappa_{kl}} = \sum_{m,n} Q_{im}^f Q_{jm}^f Q_{kn}^f Q_{ln}^f \cdot \frac{\partial \tilde{M}_m}{\partial \tilde{\kappa}_n} \\
 &+ \frac{1}{2} \sum_{\substack{m,n \\ m \neq n}} \left(\frac{(Q_{km}^f Q_{ln}^f + Q_{lm}^f Q_{kn}^f)(Q_{in}^f Q_{jm}^f + Q_{jn}^f Q_{im}^f)}{\tilde{\kappa}_n - \tilde{\kappa}_m} \right) \tilde{M}_m \\
 (\mathbf{C}^{mf})_{ijkl} &= \frac{\partial N_{ij}}{\partial \kappa_{kl}} = \sum_{m,n} Q_{im}^m Q_{jm}^m Q_{kn}^f Q_{ln}^f \cdot \frac{\partial \tilde{N}_m}{\partial \tilde{\kappa}_n}
 \end{aligned}$$

The constraints generalized as for them are written like, cf [éq 2.2-2]:

$$\begin{aligned}
 \mathbf{N} &= \mathbf{Q}_m \tilde{\mathbf{N}} \mathbf{Q}_m^T \\
 \mathbf{M} &= \mathbf{Q}_f \tilde{\mathbf{M}} \mathbf{Q}_f^T
 \end{aligned}$$

2.7 Calculation of dissipation

By definition, the density of power of dissipation at the time of the damage is worth:

$$\dot{D} = \boldsymbol{\sigma} : \dot{\boldsymbol{\varepsilon}} - \dot{\Phi}_{ed}^S = - \sum_{j=1,2} \frac{\partial \Phi_{ed}^S}{\partial d_j} \dot{d}_j = \sum_{j=1,2} Y_j \dot{d}_j$$

In this expression, one used the definition of Y_j [éq. 2.3-2]. In the damaging phase, the functions thresholds always satisfy $f_{d_j} = Y_j - k_0 \equiv 0$. Consequently, one can calculate the dissipation cumulated like:

$$D = \int \dot{D} dt = k_0 (d_1 + d_2) \quad (2.7-1)$$

It was shown that the cumulated dissipation of the process of damage is directly related to the internal variables. It is enough to make the sum of the two contributions and to multiply it by the constant of threshold k_0 .

The calculation of dissipation is carried out by the options DISS_ELGA and DISS_ELNO of CALC_CHAMP. These fields have only one named component ENDO.

2.8 Internal variables of the model

The model requires two internal variables, d_1 and d_2 (corresponding to the variables $V1$ and $V2$ Code_Aster), which represents the damage on the side of the higher face and the side of the lower face, respectively. The distinction between the faces higher and lower is carried out through the orientation of the local reference mark of each point of Gauss. Thus, the lower face is damaged with $\dot{d}_2 > 0$ for positive curves, and the higher face with $\dot{d}_1 > 0$ for negative curves, which results directly from the definition from ξ_f , (cf section 2.1).

In any case the choice of the orientation of the reference mark in a point of Gauss does not affect the final result with regard to displacements and rotations. There can be an impact on the interpretation of the damage and the generalized constraints if the local orientations are not coherent in a structure. It is strongly advised to ensure this coherence by informing the keyword ANGL_REP with the nautical angles of the local reference mark, (see [U4.42.01]):

AFPE_CARA_ELEM (HULL = _F (ANGL_REP = (a, b)))

Besides the variables $V1$ and $V2$, one introduces too $V3$ and $V4$, of binary value (0 or 1), which indicates the instantaneous evolution of $V1$ and $V2$. More precisely, $V3$ is worth 1 when $V1$ evolve and 0 if not. In the same way, $V4$ 1 is worth when $V2$ evolve and 0 if not.

ON introduces too $V5$, $V6$ and $V7$, of which the role is to measure the relative weakening of stiffness of the reinforced concrete flagstone in a rational way, for example by visualization in each material point:

$$V5 = 1 - \frac{1}{2} \left(\frac{1 + \gamma_{mi} d_1}{1 + d_1} + \frac{1 + \gamma_{mi} d_2}{1 + d_2} \right) \quad V6 = 1 - \frac{1}{2} \left(\frac{\alpha_c + \gamma_{mc} d_1}{\alpha_c + d_1} + \frac{\alpha_c + \gamma_{mc} d_2}{\alpha_c + d_2} \right) \quad \text{and}$$
$$V7 = 1 - \text{Max} \left(\frac{1 + \gamma_f d_1}{1 + d_1}, \frac{1 + \gamma_f d_2}{1 + d_2} \right)$$

respectively in traction, in compression and inflection. These variables will be always understood enters 0 and them $1 - \gamma$, respective, and will be always increasing, being worthless in absence of damage. These variables are more "speaking" that the variables $V1$ and $V2$.

The internal variables are introduced $V8$, $V9$, $V10$ and $V11$, in order to facilitate postprocessings of the reinforcements. These variables depend on the limiting deformations EPSI_ELS (limit with ELS) and EPSI_LIM (limit with the ELECTED OFFICIAL), which is provided via $\text{DEFI_MATERIAU/GLRC_DM}$.

- $V8$: ACIXELS : ruffleport enters the deformation of steel direction X (maximum between the tablecloth lower and higher) and the deformation EPSI_ELS
- $V9$: ACIXELU : ruffleport enters the deformation of steel direction X (maximum between the tablecloth lower and higher) and the deformation EPSI_ELU . It is pointed out that the model GLRC_DM do not model the plasticization of steels and is thus not predictive in this field.
- $V10$: ACIYELS : ruffleport enters the deformation of steel the direction Y (maximum enters the lower and higher tablecloth) and deformation EPSI_ELS
- $V11$: ACIYELU : ruffle port enters the deformation of steel the direction Y (maximum enters the lower and higher tablecloth) and deformation EPSI_ELU . It is pointed out that the model GLRC_DM do not model the plasticization of steels and is thus not predictive in this field.

For the concrete, the internal variables are introduced $V12$ and $V13$.

- $V12$: BETSUP : ruffleport enters the principal deformation weakest (in compression) of the concrete opposite higher and the limiting deformation the concrete in compression EPSI_C .
- $V13$: Study BureauINF : ruffleport enters the principal deformation weakest (in compression) of the concrete opposite inférieure and the deformation limits concrete in compression EPSI_C .

To trace the maxima of the deformations, one introduces $V14$, $V15$ and $V16$:

- $V14$: TRAMAX : Dmaximum eformation temporal in traction
- $V15$: COMAX : Dmaximum eformation temporal in compression
- $V16$: FLEM AX : D maximum eformation temporal in inflection

To evaluate the validity of the parameters, one proposes the calculation of the following errors:

- $V17$: ERRCOM : Error expressed as a percentage between the surfaces of the curve in theoretical compression (defined by EPSI_C and FCJ) and the approximated curve (NYC , GAMMA_C) between 0 and COMAX

- $V18$: ERRFLE: er ror expressed as a percentage between the surfaces of the curve in theoretical inflection (calculation of reinforced concrete section) and the approximated curve (MFY , $GAMMA_F$) between 0 and $FLEM AX$

2.9 Use of the model GLRC_DM in thermomechanical situations

It is admitted that the distribution of temperature is closely connected in the thickness: that is acceptable for a plate in stationary thermal situation. The thermal dilation coefficient is supposed to be that concrete, definitely majority in the section: it is thus directly used in the situations of membrane and inflection of the plate.

It is also admitted that the coefficients and parameters materials do not depend on the temperature in the studied range.

This distribution of temperature closely connected in the thickness thus results in a membrane deformation and a variation of curve thermics, from where a simple shift of the membrane deformations and curves according to the temperatures in wall of the plate.

Thus, once this operated shift, it does not have there not direct impact on the expression of the law of behavior nor on the calculation of the irreversible evolutions. Two tests check the got results, cf. § 4 .

The model GLRC_DM can thus be used in thermomechanical situations stationary without modifications, within this framework of assumptions.

3 Parameters of the law

The model of reinforced concrete endommageable flagstone `GLRC_DM` thus needs for parameters characteristic of elasticity, supplemented of 6 parameters to describe the behavior of damage: k_0 , to define the yield stress, α to determine the participation of the inflection (see § 2.2), γ_{mt} , γ_{mc} and α_c , γ_f to describe the nonlinear answer. All these parameters can be identified starting from inflection and monotonous uniaxial pure tensile tests. Some of them are replaced in the data file `Code_Aster` by "speaking" parameters more, to see hereafter with the § 3.2.5.

It is possible to proceed is starting from simple analytical estimates (which give the orders of magnitude) that is to say starting from a retiming on a response curve provided by another model of behavior, possibly by integrating compromises.

One describes in the paragraphs below the approach and one draw up the balance sheet with the § of it 3.2.5.

3.1 Identification of the parameters of linear elastic behavior

In this model one supposes that the reinforced concrete medium is homogenized and one leaves to the user the care to choose (to calculate or measure) the parameters: E_{eq}^m (effective Young modulus out of membrane), E_{eq}^f (effective Young modulus in inflection), ν_m (effective Poisson's ratio out of membrane) and ν_f (effective Poisson's ratio in inflection). One applies the following relations to determine the coefficients of Lamé λ_m , μ_m and λ_f , μ_f :

$$\begin{aligned} \lambda_m &= \frac{\nu_m E_{eq}^m h}{(1+\nu_m)(1-2\nu_m)} , & \mu_m &= \frac{E_{eq}^m h}{2(1+\nu_m)} \\ \lambda_f &= \frac{\nu_f E_{eq}^f h^3}{12(1-\nu_f^2)} , & \mu_f &= \frac{E_{eq}^f h^3}{24(1+\nu_f)} \end{aligned} \quad (3.1-1)$$

The relations above are not interchangeable by $F \leftrightarrow M$ for the parameters membrane and inflection, since out of membrane the relations correspond to the case general (elasticity 3D) and the condition of plane constraints is treated within the formulation of the model, while for the inflection one placed oneself from the start in elasticity 2D with plane constraints. In the elastic range one has as follows:

$$\begin{aligned} N_{\alpha\beta} &= \frac{E_{eq}^m h}{1-\nu_m^2} \left(\nu_m \cdot \text{tr} \boldsymbol{\epsilon} \cdot \delta_{\alpha\beta} + (1-\nu_m) \epsilon_{\alpha\beta} \right) \\ M_{\alpha\beta} &= \frac{E_{eq}^f h^3}{12(1-\nu_f^2)} \left(\nu_f \cdot \text{tr} \boldsymbol{\kappa} \cdot \delta_{\alpha\beta} + (1-\nu_f) \kappa_{\alpha\beta} \right) \end{aligned}$$

α and β being indices going from 1 to 2.

By default $E_{eq}^m = E_{eq}^f = E$ and $\nu_m = \nu_f = \nu$, where E and ν are the elastic coefficients well informed in the command file under the keyword `ELAS`. On the other hand, as the reinforced concrete is not a homogeneous material, the actual value of E_{eq}^f can be different from E_{eq}^m . Consequently,

one leave to the user the possibility of introducing values E_{eq}^f and ν_f (EF and NUF under the keyword factor GLRC_DM) different from E and ν , which in this case is only used for to describe elasticity out of membrane.

The condition of the plane constraints for the membrane $\sigma_{zz}=0$ is satisfied with the manner described in the § 2.3.

Note:

In [eq. 3.1-1], one obtains a different relation enters λ_f , ν_f and E_{eq}^f on the one hand, and enters λ_m , ν_m and E_{eq}^m in addition. This difference is directly related to the catch in account different in membrane and in inflection condition of plane constraints. More particularly, one defines E_{eq}^f and ν_f through a pure deflection test, where $\kappa_{yy} = -\nu_f \kappa_{xx}$, and $M_{ij} = 0$, except $M_{xx} \neq 0$. One makes use then of the following equations to find the relation enters λ_f , μ_f and E_{eq}^f , ν_f :

$$M_{yy} = (\lambda_f(1 - \nu_f) - 2\mu_f\nu_f)\kappa_{xx} = 0$$

and

$$M_{xx} = (\lambda_f(1 - \nu_f) - 2\mu_f)\kappa_{xx} = \frac{E_{eq}^f h^3}{12} \kappa_{xx}$$

from where one obtains:

$$E_{eq}^f = \frac{12}{h^3} (\lambda_f(1 - \nu_f) + 2\mu_f) \quad \text{and} \quad \lambda_f(1 - \nu_f) - 2\mu_f\nu_f = 0 \quad (3.1-2)$$

By solving [eq. 3.1-2], there are the relations expressed in [eq. 3.1-1].

Identification of the elastic parameters E_{eq}^m , ν_m , E_{eq}^f and ν_f model starting from the characteristics of the concrete and steels rest on two cases of loading: pure traction and pure inflection.

Let us consider the following characteristics for the concrete: Young modulus E_b , Poisson's ratio ν_b , thickness of the flagstone h , and for steels: Young modulus E_a , Poisson's ratio ν_a , total section per linear meter (for the two tablecloths, presumedly symmetrical in the thickness and identical in the two directions) S_a , relative position of a tablecloth in the thickness $\chi_a \in]0, 1[$.

One obtains thus by the uniaxial test in **pure elastic traction** :

$$\begin{aligned} N_{xx} &= E_{eq}^m h \epsilon_{xx} = E_a S_a \epsilon_{xx} + \frac{E_b h}{1 - \nu_b^2} (\epsilon_{xx} + \nu_b \epsilon_{yy}) \\ N_{yy} &= 0 = E_a S_a \epsilon_{yy} + \frac{E_b h}{1 - \nu_b^2} (\epsilon_{yy} + \nu_b \epsilon_{xx}) \end{aligned} \quad ; \quad \epsilon_{yy} = -\nu_m \epsilon_{xx} \quad (3.1-3)$$

From where (keywords E and NAKED):

$$E_{eq}^m = E_a \frac{S_a}{h} + E_b \cdot \frac{E_b h + E_a S_a}{E_b h + E_a S_a (1 - \nu_b^2)} \quad ; \quad \nu_m = \nu_b \cdot \frac{E_b h}{E_b h + E_a S_a (1 - \nu_b^2)} \quad (3.1-4)$$

One observes that this identification produced an error on the stiffness in elastic shearing plan of the flagstone, case for which steels do not contribute (they are grids of welded stems), which makes the behavior homogenized orthotropic and not isotropic. Indeed, one obtains with the values [éq.3.1-4]:

$$G_{eq}^m = \frac{E_{eq}^m}{2(1+\nu_m)} = \frac{E_b}{2(1+\nu_b)} \cdot \frac{E_b^2 h^2 + 2 E_a E_b h S_a + E_a^2 S_a^2 (1-\nu_b^2)}{E_b^2 h^2 + E_a E_b h S_a (1-\nu_b)} \neq \frac{E_b}{2(1+\nu_b)} \quad (3.1-5)$$

If one prefers to firstly ensure the identification on the case of **elastic shearing plan** flagstone, and on the case of the answer according to the direction of pure traction (thus by accepting the error on the effect orthogonal Fish), one obtains:

$$E_{eq}^m = E_b + \frac{E_a S_a (1-\nu_b)}{h} ; \nu_m = \nu_b + \frac{E_a S_a (1-\nu_b^2)}{E_b h} ; G_{eq}^m = \frac{E_b}{2(1+\nu_b)} \quad (3.1-6)$$

One will take care so that this coarse identification (nonacceptable thermodynamically compared to the pure tensile test) does not give whimsical values of ν_m .

Then, one obtains by the uniaxial test in **pure elastic inflection** :

$$M_{xx} = \frac{E_{eq}^f h^3}{12} \kappa_{xx} = \frac{1}{4} E_a S_a h^2 \chi_a^2 \kappa_{xx} + \frac{E_b h^3}{12(1-\nu_b^2)} (\kappa_{xx} + \nu_b \kappa_{yy}) \quad ; \kappa_{yy} = -\nu_f \kappa_{xx} \quad (3.1-7)$$

$$M_{yy} = 0 = \frac{1}{4} E_a S_a h^2 \chi_a^2 \kappa_{yy} + \frac{E_b h^3}{12(1-\nu_b^2)} (\kappa_{yy} + \nu_b \kappa_{xx})$$

From where (keywords EF and NUF):

$$E_{eq}^f = \frac{3}{h} E_a S_a \chi_a^2 + E_b \cdot \frac{E_b h + 3 E_a S_a \chi_a^2}{E_b h + 3 E_a S_a \chi_a^2 (1-\nu_b^2)} ; \nu_f = \nu_b \cdot \frac{E_b h}{E_b h + 3 E_a S_a \chi_a^2 (1-\nu_b^2)} \quad (3.1-8)$$

One also observes that this identification produced an error on the stiffness in anticlastic elastic inflection M_{xy} flagstone (coefficient $G_{eq}^f = \frac{E_{eq}^f h^3}{24(1+\nu_f)}$ instead of $G_b^f = \frac{E_b h^3}{24(1+\nu_b)}$), case for which steels do not contribute.

3.2 Identification of the parameters of elastic behavior endommageable

The way in which one obtains the parameters of linear elasticity being presented to the § 3.1, one proposes to calculate the parameters of damage of the model from three tests: a pure tensile test, a test of pure compression and a uniaxial monotonous pure deflection test.

In this manner one obtains the values of the threshold k_0 , three parameters relating to the effects of membrane (γ_{mt} , α_c and γ_{mc}) independently of the two parameters relating to the effects of inflection (α , γ_f).

3.2.1 Parameters of traction (keywords `NYT`, `GAMMA_T`)

3.2.1.1 Threshold of appearance of the damage in traction `NYT`

In particular, for **traction** rubber band **uniaxial pure** with the appearance of the damage one can write the value of the threshold, cf [éq. 2.3-2]:

$$f_{d_j} = Y_j^m - k_0 = \epsilon_D^2 \left(\frac{\lambda_m}{4} (1 - 2\nu_m)^2 (1 - \gamma_{mt}) + \frac{\mu_m}{2} \left(1 - \gamma_{mt} + \nu_m^2 \frac{1 - \gamma_{mc}}{\alpha_c} \right) \right) - k_0 = 0$$

ϵ_D being elastic strain with the appearance of the damage, having then $\epsilon_{yy} = -\nu_m \epsilon_D = \epsilon_{zz}$ and $\xi_m(x, 0, 0) = 1$, from where:

$$k_0 = \frac{\lambda_m (1 - 2\nu_m)^2 (1 - \gamma_{mt}) + 2\mu_m \left(1 - \gamma_{mt} + \nu_m^2 (1 - \gamma_{mc}) / \alpha_c \right)}{4(\lambda_m (1 - 2\nu_m) + 2\mu_m)^2} N_D^2, \text{ that is to say:} \quad (3.2-1)$$

$$k_0 = \frac{N_D^2}{4 E_{eq}^m h (1 + \nu_m)} \cdot \left((1 - \nu_m)(1 + 2\nu_m)(1 - \gamma_{mt}) + \nu_m^2 (1 - \gamma_{mc}) / \alpha_c \right)$$

having

$$N_D = (\lambda_m (1 - 2\nu_m) + 2\mu_m) \epsilon_D = E_{eq}^m h \epsilon_D$$

Note:

It is pointed out that $\gamma_{mt} \leq 1$ (cf éq. 3.2-2) and that $\gamma_{mc} \leq 1$ so that the damage results well in a weakening of the stiffness. One also observes on [éq. 3.2-1] that one cannot have at the same time $\gamma_{mt} = 1$ and $\gamma_{mc} = 1$, because then $k_0 = 0$ (the model does not have an elastic range), or then it would be necessary to give $N_D = \infty$ (keyword `NYT`).

By continuing the analysis made with 3.1, just with the appearance of the damage, the longitudinal constraint in the concrete is worth:

$$E_b \epsilon_D \frac{1 - \nu_b \nu_m}{1 - \nu_b^2}$$

so that one can express the threshold N_D (keyword `NYT`) with the limit of cracking of the concrete σ_b^t in traction, while supposing validates the local criterion $\sigma_{xx} \leq \sigma_b^t$:

$$N_D = \sigma_b^t \frac{E_{eq}^m h}{E_b} \cdot \frac{1 - \nu_b^2}{1 - \nu_b \nu_m} \quad (3.2-2)$$

3.2.1.2 Parameter of degradation of stiffness in traction `GAMMA_T`

LE parameters γ_{mt} beT equal to the relationship between the slope corresponding to the rigidity of the damaged phase, provided by the keyword `SLOPETRACTION` in `DEFI_GLRC` and the slope corresponding to elastic rigidity.

For recall (see U4.42.06), three methods called `RIGI_ACIER`, `PLAS_ACIER` and `UTIL` are available. These three calculations of slopes make it possible to set up three different methods of retiming according to the properties materials informed for traction. If the yield stress of steels is not known, methods of retiming `RIGI_ACIER`, i.e slope post-rubber band equalizes with the slope of resumption of stiffness of steels, and `UTIL`, i.e slope post-rubber band cuts the slope of resumption of stiffness of steels to a maximum deformation whose value is imposed by the user, are accessible (cettE method is not adapted for maximum deformations weaker than the hollow of the curve of reference, to see Figure 3.2.1.2-b). If the elastic limit of steels is known, it is possible to use the method of retiming to the plastic limit of steels (`PLAS_ACIER`). The various methods of retiming are illustrated by the figures which follow.

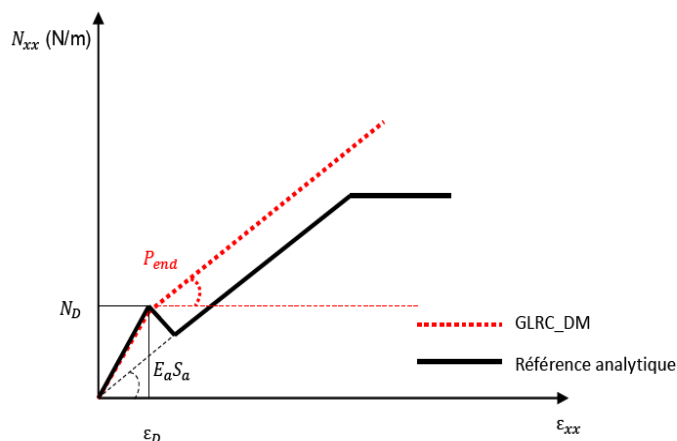

Figure 3.2.1.2-a: Traction diagram (GLRC_DM vs Référence) Retiming SLOPE = RIGI_ACIER

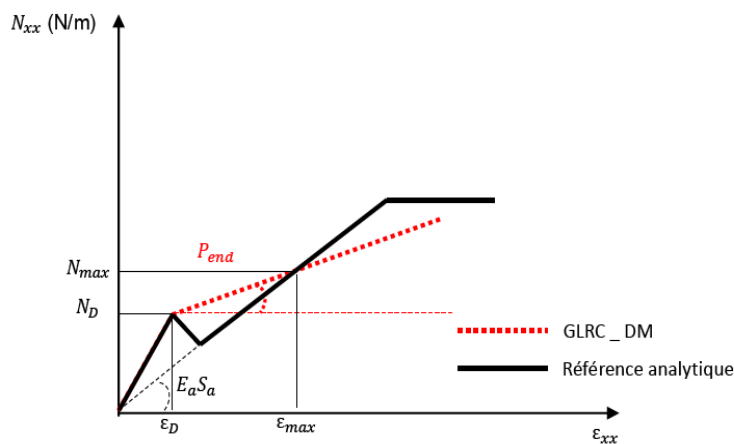

Figure 3.2.1.2-b: Traction diagram (GLRC_DM vs Référence) Retiming SLOPE = UTIL

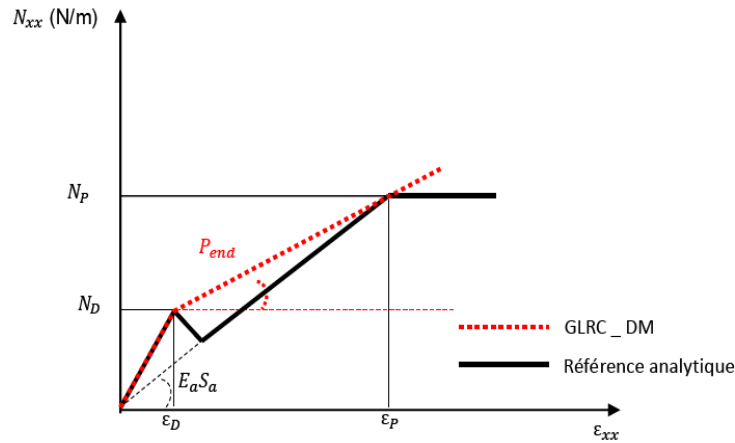

Figure 3.2.1.2-c: Traction diagram (GLRC_DM vs Référence) Retiming SLOPE = PLAS_ACIER

3.2.1.3 Case distortion uniaxial pure

Let us check the effect of these parameters on the appearance of the damage following a loading of **pure distortion** rubber band $\epsilon_{xy} = \tilde{\epsilon}_1 = -\tilde{\epsilon}_2$, with $\epsilon_{xx} = \epsilon_{yy} = 0$. As follows: $N_{xy} = \tilde{N}_1 = -\tilde{N}_2 = 2 \mu_m \epsilon_{xy}$. The threshold of appearance of the damage [éq. 2.3-2] with the model GLRC_DM is reached for the shearing force:

$$N_{xy}^D = 2 \frac{\sqrt{2 \mu_m k_0}}{\sqrt{1 + \alpha_c - \gamma_{mc} - \gamma_{mt} \alpha_c}} = \frac{N_D}{1 + \nu_m} \sqrt{\frac{(1 - \nu_m)(1 + 2 \nu_m)(1 - \gamma_{mt}) + \nu_m^2 (1 - \gamma_{mc}) / \alpha_c}{1 + \alpha_c - \gamma_{mc} - \gamma_{mt} \alpha_c}}$$

It can be useful to confront this prediction with that which one obtains with the concrete model ENDO_ISOT_BETON [R7.01.04], [2.3.2.3], with the limit of cracking of the concrete σ_b^t in traction:

$$N_{xyEIB}^D = 2 \sigma_b^t h \sqrt{\frac{(1 - \nu_b)(1 + 2 \nu_b)}{(1 + \nu_b)^2}} = 2 N_D \frac{E_b (1 - \nu_b \nu_m)}{E_{\acute{e}q}^m (1 - \nu_b^2)} \sqrt{\frac{(1 - \nu_b)(1 + 2 \nu_b)}{(1 + \nu_b)^2}}$$

Note:

In any situation combined (compression+cisaillement, etc) into membrane pure, the expression of the threshold of first damage $Y_j^m = k_0$ model GLRC_DM, cf [éq. 2.3-2], according to the membrane efforts $N_{xx}, N_{xy} \dots$, is made up by the same students' rag processions as the "usual" criterion in plane constraints of the material concrete considered not to resist beyond σ_b^t . This comes from the choice of the formulation of the model GLRC_DM out of membrane, direct filiation of the model ENDO_ISOT_BETON.

3.2.2 Parameters of compression (keywords NYC, GAMMA_C, ALPHA_C)

In compression, three parameters are to be determined: N_C , α_c and γ_{mc} . One uses three equations to reach that point.

The first comes us from the formulation of the model. If one considers a test of **pure uniaxial pressing**, the value of the threshold of first damage, cf [éq. 2.3-2], is written while indicating by N_C normal effort corresponding:

$$k_0 = \frac{N_C^2}{4 E_{\text{eq}}^m h (1 + \nu_m)} \left((1 - \nu_m)(1 + 2 \nu_m) \frac{1 - \gamma_{mc}}{\alpha_c} + \nu_m^2 (1 - \gamma_{mt}) \right)$$

One must thus necessarily have the relation:

$$\frac{N_C^2}{N_D^2} = \frac{\alpha_c (1 - \nu_m)(1 + 2 \nu_m)(1 - \gamma_{mt}) + \nu_m^2 (1 - \gamma_{mc})}{(1 - \nu_m)(1 + 2 \nu_m)(1 - \gamma_{mc}) + \alpha_c \nu_m^2 (1 - \gamma_{mt})}$$

Thus, one obtains the expression of α_c according to γ_{mc} , γ_{mt} , and N_D , N_C :

$$\begin{aligned} \gamma_{mc} &= 1 - \alpha_c (1 - \gamma_{mt}) \cdot \frac{N_D^2 (1 - \nu_m)(1 + 2 \nu_m) - N_C^2 \nu_m^2}{N_C^2 (1 - \nu_m)(1 + 2 \nu_m) - N_D^2 \nu_m^2} \\ \Leftrightarrow \alpha_c &= \frac{(1 - \gamma_{mc})}{(1 - \gamma_{mt})} \cdot \frac{N_C^2 (1 - \nu_m)(1 + 2 \nu_m) - N_D^2 \nu_m^2}{N_D^2 (1 - \nu_m)(1 + 2 \nu_m) - N_C^2 \nu_m^2} \end{aligned} \quad (3.2-3)$$

Note:

It is necessary that $\gamma_{mc} \leq 1$, just like $\gamma_{mt} \leq 1$, cf [éq. 2.3-2]. One also recalls, cf [éq. 3.2-1], that one cannot have at the same time $\gamma_{mt} = 1$ and $\gamma_{mc} = 1$. [Éq. 3.2-3], one obtains the requirement, whatever α_c :

$$|N_C| \leq N_D \frac{\sqrt{(1 - \nu_m)(1 + 2 \nu_m)}}{\nu_m}$$

Equality in the relation above conduit with $\gamma_{mc} = 1$.

For reinforced concrete, having $\nu_m \approx 0,2$, this condition is written: $|N_C| < 5,2 N_D$.

second equation comes from an additional condition which one imposes: one aims at the same maximum damage in traction and compression. d_{max} thus corresponds to the loss of the most important stiffness, at the same time in traction (noted ξ_t_{min}) and in compression (noted ξ_c_{min}).

Lastly, ON introduced a variable N_{CU} who corresponds to the ultimate resistance of the section in compression, starting from the height H of the hull, and the value of average resistance in compression F_{CJ} and ϵ_{CI} corresponding deformation.

$$N_{CU} = h F_{CJ} + E_a S_a \epsilon_{CI} \quad (3.2-4)$$

LE threshold of compression N_C is then related to the ultimate limit of compression N_{CU} via the equation:

$$N_C = \frac{N_{CU} - \gamma_{mc} h E_m \epsilon_{CI}}{1 - \gamma_{mc}} \quad (3.2-5)$$

One aims at the same maximum damage in traction and compression. d_{max} thus must allow TRe to reach the loss of the most important stiffness, at the same time in traction (noted $\xi_{t_{min}}$) and in compression (noted $\xi_{c_{min}}$). In compression, the maximum damage makes it possible to reach the peak of compression N_{CU} . In traction, it makes it possible to reach the point of plasticization of steels.

$$\frac{\alpha_c + \gamma_{mc} d_{max}}{\alpha_c + d_{max}} = \xi_{c_{min}} = \frac{N_{CU}}{h E_m^m \epsilon_{CI}} \quad (3.2-6)$$

$$\frac{1 + \gamma_{mt} d_{max}}{1 + d_{max}} = \xi_{t_{min}} = \frac{S_a \sigma_{ya}}{h E_m \epsilon_{tmax}} = \frac{S_a \sigma_{ya}}{N_D + (S_a \sigma_{ya} - N_D) / \gamma_{mt}} \quad (3.2-7)$$

The resolution of the equation [éq. 3.2-7] give the value of the maximum damage d_{max} .

$$d_{max} = \frac{S_a \sigma_{ya} - N_D}{N_D * \gamma_{mt}}$$

If the value obtained for d_{max} is positive, one obtains:

$$\alpha_c = \frac{d_{max} N_C (1 - \gamma_{mc})}{h E_m \epsilon_{CI} - N_{CU}} \text{ yew is necessarily necessary to have } N_{CU} < h E_m \epsilon_{CI}$$

and

$$\frac{d_{max} N_C}{h E_m \epsilon_{CI} - N_{CU}} = \frac{(N_D^2 v_m^2 - N_C^2 (1 - v_m)(1 + 2 v_m))}{(1 - \gamma_{mt})(N_C^2 v_m^2 - N_D^2 (1 - v_m)(1 + 2 v_m))}$$

This last equation is a cubic equation N_C

In the case or $d_{max} < 0$, one modifies the calculation of γ_{mt} , while imposing $\gamma_{mt} = 0$

and the equation [éq. 3.2-7] is modified by

$$\frac{1}{1 + d_{max}} = \frac{S_a \sigma_{ya}}{h E_m \epsilon_{tmax}} \text{ with } \epsilon_{tmax} = \frac{\sigma_{ya}}{E_a}$$

then one has $d_{max} = \frac{h E_m}{S_a \sigma_{ya}} - 1$.

3.2.3 Parameters of inflection (keywords MYF , GAMMA_F)

3.2.3.1 Options RIGI_ACIER and PLAS_ACIER

EN inflection rubber band uniaxial pure only one damage mechanism is activated, according to its direction, positive or negative. Here the positive inflection is chosen, for which one always has

Warning : The translation process used on this website is a "Machine Translation". It may be imprecise and inaccurate in whole or in part and is provided as a convenience.

Copyright 2021 EDF R&D - Licensed under the terms of the GNU FDL (<http://www.gnu.org/copyleft/fdl.html>)

$f_{d_1} > f_{d_2}$. The value maximum of elastic curve κ_{xx} with the appearance of the damage is noted κ_D ($\kappa_{yy} = -\nu_f \kappa_{xx}$), such as only the threshold $f_{d_1} = 0$ can be reached, while $f_{d_2} < 0$ for each point of this trajectory of the loading, cf [éq. 2.3-2]:

$$f_{d_1} = Y_1^f - k_0 = \kappa_D^2 \frac{(1-\gamma_f)}{\alpha} \left(\frac{\lambda_f}{2} (1-\nu_f)^2 + \mu_f \right) - k_0$$

from where:

$$\alpha = (1-\gamma_f) \frac{\lambda_f (1-\nu_f)^2 + 2\mu_f}{2(\lambda_f (1-\nu_f) + 2\mu_f)^2} \frac{M_D^2}{k_0} \quad (3.2-8)$$

having

$$M_D = (\lambda_f (1-\nu_f) + 2\mu_f) \cdot \kappa_D = \frac{E_{eq}^f h^3}{12} \kappa_D$$

As the reinforced concrete plate is supposed to be symmetrical compared to the average layer, one needs to make the identification only for the positive inflection (the negative inflection giving the same value).

By continuing the analysis made with the § 3.1, just with the appearance of the damage, the longitudinal constraint in the concrete is worth in wall of the plate (it is known that then the damage progresses immediately in a good portion thickness of the section):

$$E_b \kappa_D h \frac{1-\nu_b \nu_f}{2(1-\nu_b^2)}$$

so that one can express the threshold M_D with the limit of cracking of the concrete σ_t^b :

$$M_D = \sigma_t^b \frac{E_{eq}^f h^2}{6 E_b} \cdot \frac{1-\nu_b^2}{1-\nu_b \nu_f} \quad (3.2-9)$$

This value is used for the parameter settings RIGI_ACIER and PLAS_ACIER of operand PENTE/FLEXION of DEFI_GLRC.

LE parameters γ_f beT equal to the relationship between the slope corresponding to the rigidity of the damaged phase, provided by the keyword SLOPEINFLECTION in DEFI_GLRC and the slope corresponding to elastic rigidity. Options RIGI_ACIER and PLAS_ACIER correspond to the behavior presented for traction to 3.2.1.2.

In order to more accurately represent the behavior of the reinforced concrete in inflection for a range of more restricted curve, D they methods are introduced for the identification of the parameters in inflection.

These two methods are based on the first identification of the theoretical curve curve-inflection of the section. This theoretical curve is given from the theoretical one of the plane section.

The answer of the section is calculated by integrating the answers on the height of the section.

The assumptions of answer for each material are the following ones:

- Non-linear answer of the concrete defined by the limit in traction SYT , the limit in compression SYC and the parameter C which determines the value of the slope of behaviour in traction of the concrete after cracking. $C=5$ is retained, i.e. that the slope after cracking is worth $-0.2 P_{elas}$, where P_{elas} is elastic slope. It is about a compromise evaluated starting from digital tests of tensile with the law `ENDO_ISOT_BETON` for concrete classes usually used by engineering. The assumption is added that the limit in compression is higher than the limit in traction (in absolute value) $|SYC| > |SYT|$.

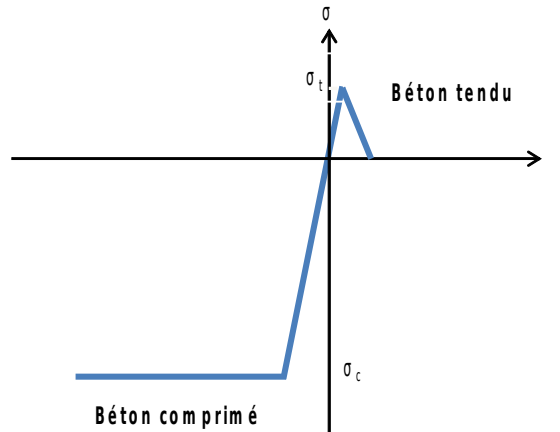

Figure 3.2.3.1-a: Behavior of the concrete for the calculation of the curved curve-moment

- Elastoplastic answer of the steel defined by parameter SY

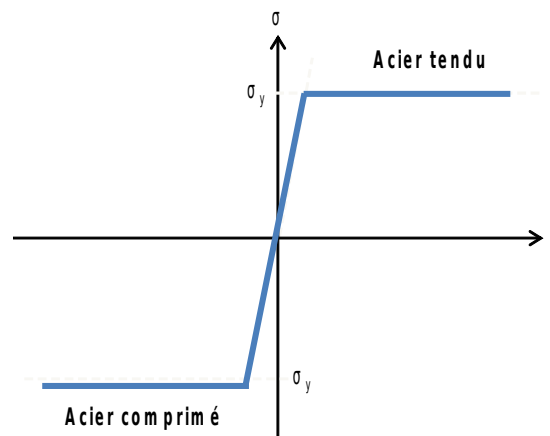

Figure 3.2.3.1-b : Behavior of the steel for the calculation of the curved curve-moment

To determine the answer curve-inflection, one leaves the assumption of a resultant of axial load no one. For the data of a curve, one determines the value of the deformation to the neutral axis in order to obtain a resultant of axial load no one. This determination is carried out by making assumption on the possible states (cracking of the concrete, limiting in compression reached, plasticization of steels... etc). She does not call on a digital integration with a criterion of precision, which makes its use surer and less expensive.

The moment is then given starting from the values of the deformation to the neutral axis and the curve.

Note:

In the case of the modeling of the section of the hull proposedE, the module of inflection obtained is worth :

$$E_{eq}^f = \frac{3}{h} E_a S_a \chi_a^2 + E_b$$

It thus differs from the module which takes into account the Poisson's ratio [éq. 3.1-8]. To ensure the coherence of the formulas and to get same the results in elastic inflection, one uses a Young modulus of the concrete modified in the calculation of the answer of the section via integration in the height.

$$\tilde{E}_b = E_b \cdot \frac{E_b h + 3 E_a S_a \chi_a^2}{E_b h + 3 E_a S_a \chi_a^2 (1 - \nu_b^2)}$$

Two options are available for the determination of the bilinear approximation of curve curve moment-curve.

3.2.3.2 Option RIGI_INIT

For the option of identification RIGI_INIT , one defines the bending moment in the following way threshold corresponding to the appearance of the damage:

- From the point of initiation of the first crack M_D , one searches the smallest moment on the elastic curve, for which the variation with the theoretical curve exceeds 5%. This moment is appointed for the value MYF .
- The slope of damage in uniaxial pure inflection is then defined like the slope of the tangent to the theoretical curve moment-curve and passing by the point definite threshold.
- The parameter γ_f is then defined like the report of the slopes damaging and elastic.

Note:

For sections with little reinforcement, one can obtain a negative slope endommagente. $\gamma_f < 0$. In this case a message of alarm is displayed, one imposes a slope $\gamma_f = 10^{-3}$ and the moment threshold MYF is tiny room to satisfy the condition with tangent to the theoretical curve.

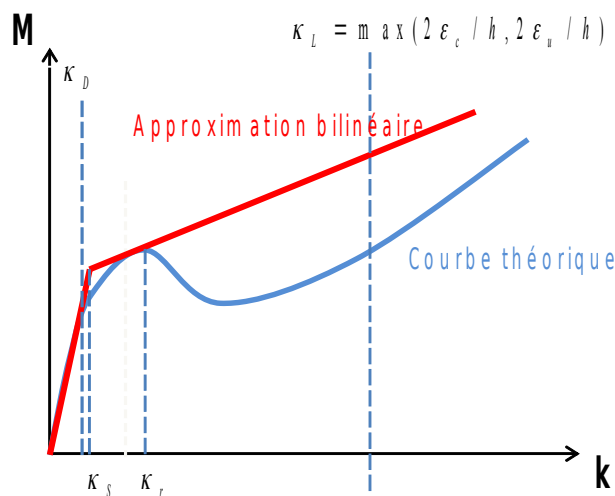

Figure 3.2.3.2-a : Bilinear approximation in inflection with the option RIGI_INIT

For the implementation of this option, the following stages are carried out:

- For each curve, in an interval of curves $[\kappa_D, \kappa_L]$, the theoretical moment is determined M and the tangent $dM/d\kappa$ with the curve ($d\kappa = (\kappa_L - \kappa_D)/1000$). This tangent is obtained by finished difference.
- Among the computed values, one selects the first curve for which the variation with the curve is higher than 5%.
- To obtain the slope of damage, the limiting curve is selected κ_R for which one minimizes the difference enters $dM/d\kappa$ and the slope of damage.

3.2.3.3 Option UTIL

For the option of identification UTIL, the definite userT a value of curve targets via the keyword KAPPA_FLEX. One then determines the value of the curve and the moment sueil κ_s and MYF in order to minimize the surface enters the theoretical curve and the bilinear curve.

Note:

For sections with little reinforcement, one can obtain a negative slope damage. $\gamma_f < 0$. In this case a message of alarm is displayed, one imposes a slope $\gamma_f = 10^{-3}$ and the moment threshold MYF is defined with the limit of cracking of the concrete, i.e. M_D .

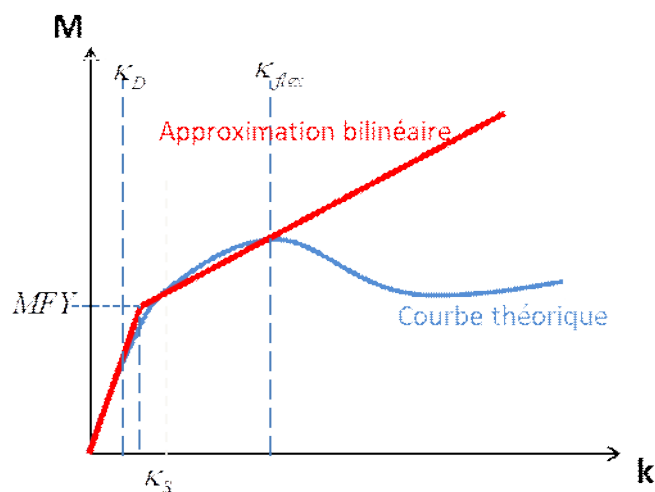

Figure 3.2.3.3-a : Bilinear approximation in inflection with the option UTIL

For the implementation of this option, the following stages are carried out:

- For each curve, in an interval of curves $[\kappa_D, \kappa_{flex}]$ (1000 points), the theoretical moment is determined M and one calculation the surface under the theoretical curve by the method of the rectangles, as well as the surface under the bilinear curve.
- One evaluates the surface under the curve of the bilinear approximations which guarantee the elastic slope calculated beforehand and which cut the theoretical curve for $\kappa = \kappa_{flex}$: the point threshold is moved along the elastic slope and the damaged slope adjusted to pass by the theoretical curve.
- O N retains the bilinear approximation which minimizes the difference between the surface under its curve and that of the theoretical curve.

3.2.4 Case traction-inflection uniaxial

Let us check the effect of these parameters on the appearance of the damage following a mixing loading **traction** monotonous uniaxial and **inflection** monotonous uniaxial concomitant. The thresholds are written, for each variable of damage:

$$k_0 \geq Y_1 = \epsilon_{xx}^2 \left(\frac{\lambda_m}{4} (1-2\nu_m)^2 (1-\gamma_{mt}) + \frac{\mu_m}{2} \left(1-\gamma_{mt} + \nu_m^2 \frac{1-\gamma_{mc}}{\alpha_c} \right) \right) + \kappa_{xx}^2 \nu_f^2 \mu_f \frac{(1-\gamma_f)}{\alpha}$$

$$k_0 \geq Y_2 = \epsilon_{xx}^2 \left(\frac{\lambda_m}{4} (1-2\nu_m)^2 (1-\gamma_{mt}) + \frac{\mu_m}{2} \left(1-\gamma_{mt} + \nu_m^2 \frac{1-\gamma_{mc}}{\alpha_c} \right) \right) + \kappa_{xx}^2 \frac{(1-\gamma_f)}{\alpha} \left(\frac{\lambda_f}{2} (1-\nu_f)^2 + \mu_f \right)$$

It is checked easily that $Y_1 < Y_2$: the first damage appears on the variable d_2 as expected. Let us exploit the results [éq. 3.2-1] and [éq. 3.2-3], the threshold $Y_2 = k_0$ is thus written:

$$\frac{N_{xx}^2}{N_D^2} + \frac{M_{xx}^2}{M_D^2} = 1 \quad (3.2-10)$$

It thus defines the elastic range predicted by the model GLRC_DM in the quadrant (N_{xx}, M_{xx}) positive in an elliptic form.

By continuing the analysis made with the § 3.1, just with the appearance of the damage, the longitudinal constraint in the concrete is worth:

$$\frac{E_b}{1-\nu_b^2} \left(\epsilon_{xx} (1-\nu_b \nu_m) + \kappa_{xx} \frac{h}{2} (1-\nu_b \nu_f) \right)$$

By confronting this result with the limit of cracking of the concrete σ_t^b , it is noted that one obtains an elastic range in the quadrant (N_{xx}, M_{xx}) positive of polygonal form:

$$\frac{N_{xx}}{N_D} + \frac{M_{xx}}{M_D} = 1$$

It is known that this incipient damage is followed immediately in a model 3D of the reinforced concrete plate by the appearance of a zone damaged on a good portion thickness.

This difference in prediction with the model GLRC_DM is inherent in the choice operated in [éq. 2.1-4] of an energy of plate élasto-endommageable in membrane-inflection, compound with the threshold [éq.2.3-1].

As this difference can vary between 0% and 30%, one suggests lowering the digital values of N_D and M_D defined previously from 10%.

3.2.5 Assessment of the identification of the parameters of the model GLRC_DM

One draws up the balance sheet of the simplified analytical expressions suggested in the paragraphs above, exploiting geometrical data and material of the reinforced concrete (see their definitions with the sections 3.2.1 with 3.2.4) being used to establish values to be given to the keywords of the model GLRC_DM in Code_Aster.

Parameter	keyword	Identification	Analytical expression suggested
E_{eq}^m	E	effective Young modulus out of membrane (units: force/surface)	$E_{eq}^m = E_a \frac{S_a}{h} + E_b \cdot \frac{E_b h + E_a S_a}{E_b h + E_a S_a (1 - \nu_b^2)}$
ν_m	NAKED	effective Poisson's ratio out of membrane	$\nu_m = \nu_b \cdot \frac{E_b h}{E_b h + E_a S_a (1 - \nu_b^2)}$
E_{eq}^f	EF	effective Young modulus in inflection (units: force/surface)	$E_{eq}^f = \frac{3}{h} E_a S_a \chi_a^2 + E_b \cdot \frac{E_b h + 3 E_a S_a \chi_a^2}{E_b h + 3 E_a S_a \chi_a^2 (1 - \nu_b^2)}$
ν_f	NUF	effective Poisson's ratio in inflection	$\nu_f = \nu_b \cdot \frac{E_b h}{E_b h + 3 E_a S_a \chi_a^2 (1 - \nu_b^2)}$

Note: these values can be amended to privilege the situations of loading of shearing pure plan, to see [éq. 3.1-5 and 8].

N_D	NYT	threshold in pure traction with the appearance of the damage (units: force/length)	$N_D = \sigma_b^t \frac{E_{eq}^m h}{E_b} \cdot \frac{1 - \nu_b^2}{1 - \nu_b \nu_m}$
$\gamma_{mt} \leq 1$	GAMMA_T	parameter of degradation of stiffness in traction	vto oir §3.2.1.2
N_C	NYC	threshold in pure compression with the appearance of the damage (units: force/length)	to see §3.2.2
$\gamma_{mc} \leq 1$	GAMMA_C	parameter of degradation of stiffness in compression	to see §3.2.2
$\alpha_c > 0$	ALPHA_C	Parameter of delay of appearance of the damage in compression	to see §3.2.2
M_D	MYF	threshold in pure inflection with the appearance of the damage (units: force) in the case UTIL	vto oir §3.2.3
$\gamma_f \leq 1$	GAMMA_F	parameter of degradation of stiffness in inflection	vto oir §3.2.3

Note: Lbe values of N_D and M_D can be reduced to limit the variation on the border of the elastic range for the mixed loadings in traction-inflection, to see §3.2.4. One can also check the evaluation of N_D on a situation of shearing pure plan, cf §3.2.1.3.

One will be able advantageously to use Operator `DEFI_GLRC`, to see [bib12] to obtain the identification of the parameters of the model GLRC_DM starting from the data of materials, steel and concrete, and geometry of the reinforced concrete section.

It is useful to confront these estimates with the answer given by another model of behavior – as the model ENDO_ISOT_BETON – on a simple case, to even operate a retiming on response curves, in the interval $[0, |\varepsilon_{xx}^{max}|]$ estimated in the study in sight, for example while basing itself on the CAS-test of checking SSNS106 [bib8].

4 Verification

This model is checked by the tests SSNS106A, B, C, D, E, F (to see [bib8]), by comparison with a multi-layer modeling exploiting the behavior ENDO_ISOT_BETON and elastic steel tablecloths. The studied cases are:

ssns106 has	2 ways of loading traction and compression then compression-traction $ \varepsilon_{xx}^{max} =0,0002$
ssns106 B	2 ways of loading after (inflection - + then inflection +), double cycle
ssns106 C	way of loading combined with cycling in traction 2 times faster than in inflection
ssns106 D	cycle of pure shearing
ssns106 E	cycle of combined shearing and inflection
ssns106 F and G	cycles of traction-compression and of pure shearing with <i>kit_ddi</i> GLRC_DM + VMIS_ISOT_LINE
ssns106 H	pure traction and compression, high requests $ \varepsilon_{xx}^{max} =0,001$
ssns106 I	alternate pure inflection, high requests
ssns106 J	coupling traction/compression and inflection, requests high
ssns106 K	compression - traction with ALPHA_C=100
ssns106 L	pure shearing and distortion in the plan, high requests
ssns106 m	coupling inflection and shearing in the plan, high requests
ssns106 N	anticlastic inflection, high requests
ssns106 O	requests thermal loading
ssns106 p	simple traction
ssns106 Q	simple compression

5 Validation

One will be able to consult the whole of the casestests known as of validation in the field of paraseismic calculation in non-linear transient of structures and reinforced concrete buildings indexed in [bib11].

6 Bibliography

1. LEMAITRE J., CHABOCHE J.L.: "Mechanical of solid materials", ED. Dunod (1985)
2. P.KOECHLIN, S.POTAPOV. "With total constitutive model for reinforced concrete punts". ASCE J. Eng. Mech. 2006.

3. P.KOECHLIN, S.MILL. "Model of total behavior of the reinforced concrete plates under dynamic loading in inflection: improved law GLRC: modeling of cracking by damage". Note HT-62/02/021/A, 11/2002.
4. F.VOLDOIRE. "Homogenisation of the heterogeneous structures". Note EDF/DER/MMN HI-74/93/055, 10/27/1993.
5. S.MILL. "Modeling of the reinforced concrete structures under seismic loading". Note HT-62/04/025/A, 12/2004.
6. S.MILL. F. VOLDOIRE "Study of a reinforced concrete beam under loading of inflection". Note HT-62/05/013/A, 9/2006.
7. J-J.MARIGO. "Digital study of the damage". EDF, Bulletin of the studies and research, series C, n°2, pp. 27-48, 1982.
8. [V6.05.106] SSNS106 – Damage of a plate planes under requests varied with the law of behavior GLRC_DM.
9. [R3.07.03] – Elements of plate DKT, DST, DKQ, DSQ and Q4g.
10. [R7.01.04] – Law of behavior ENDO_ISOT_BETON.
11. [A4.01.04] – File of validation of paraseismic calculation.
12. [U4.42.06] – Operator DEFI_GLRC .

7 Withnexe: Eigenvalues of the tensor of the deformations

An orthonormal base is considered $(\mathbf{e}_i)_{i=1,2,3}$ three-dimensional Euclidean space, and a tensor $\boldsymbol{\varepsilon}$ of a nature 2, symmetrical, therefore diagonalisable. One notes ε_j^i mixed components of the tensor $\boldsymbol{\varepsilon} = \varepsilon_j^i \cdot \mathbf{e}_i \otimes \mathbf{e}^{*j}$ in the base $(\mathbf{e}_i)_{i=1,2,3}$. One uses the convention of Einstein on the repeated mixed indices.

One notes: \mathbf{Q}_k, η_k the triplet of the vectors own standards and associated eigenvalues of the problem:

$$\boldsymbol{\varepsilon} \cdot \mathbf{Q}_k = \eta_k \mathbf{Q}_k \Leftrightarrow \varepsilon_j^i \cdot (\mathbf{Q}_k)^j \mathbf{e}_i = \eta_k (\mathbf{Q}_k)^i \mathbf{e}_i \quad \text{pour } k=1,2,3 \quad (7-1)$$

Note:

It is noted that: $(\boldsymbol{\varepsilon} + \xi \mathbf{Id}) \cdot \mathbf{Q}_k = (\lambda_k + \xi) \cdot \mathbf{Q}_k$, $\forall \xi \in \mathbb{R}$, therefore to add to $\boldsymbol{\varepsilon}$ any tensor diagonal does not modify the clean directions of $\boldsymbol{\varepsilon}$.

It is known that the clean vectors $(\mathbf{Q}_k)^j \mathbf{e}_j$ form an orthonormal base (principal reference mark):

$$(\mathbf{Q}_k)_i \mathbf{e}^{*i} \cdot (\mathbf{Q}_l)^j \mathbf{e}_j = \delta_{kl} \cdot \delta^{ij} \Rightarrow (\mathbf{Q}_k)_j (\mathbf{Q}_l)^j = \delta_{kl} \quad (7-2)$$

Let us differentiate these two relations:

$$(d\boldsymbol{\varepsilon})_j^i \cdot (\mathbf{Q}_k)^j + \varepsilon_j^i \cdot (d\mathbf{Q}_k)^j = d\eta_k (\mathbf{Q}_k)^i + \eta_k (d\mathbf{Q}_k)^i \quad \text{pour } k=1,2,3 \quad (7-3)$$

$$(d\mathbf{Q}_k)_j \cdot (\mathbf{Q}_l)^j + (\mathbf{Q}_k)_j \cdot (d\mathbf{Q}_l)^j = 0 \quad (7-4)$$

Let us project the equation (7-3) on the clean vector $(\mathbf{Q}_l)^i \mathbf{e}_i$ and let us use the equation (7-4):

$$\begin{aligned} (d\boldsymbol{\varepsilon})_j^i \cdot (\mathbf{Q}_k)^j (\mathbf{Q}_l)_i + \varepsilon_j^i \cdot (d\mathbf{Q}_k)^j (\mathbf{Q}_l)_i &= d\eta_k (\mathbf{Q}_k)^i (\mathbf{Q}_l)_i + \eta_k (d\mathbf{Q}_k)^i (\mathbf{Q}_l)_i \quad \text{pour } k, l=1,2,3 \\ \Leftrightarrow (d\boldsymbol{\varepsilon})_j^i \cdot (\mathbf{Q}_k)^j (\mathbf{Q}_l)_i + \eta_l \cdot (d\mathbf{Q}_k)^j (\mathbf{Q}_l)_j &= d\eta_k \cdot \delta_{kl} + \eta_k (d\mathbf{Q}_k)^i (\mathbf{Q}_l)_i \quad \text{pour } k, l=1,2,3 \\ \Leftrightarrow (d\boldsymbol{\varepsilon})_j^i \cdot (\mathbf{Q}_k)^j (\mathbf{Q}_l)_i &= d\eta_k \cdot \delta_{kl} + (\eta_k - \eta_l) \cdot (d\mathbf{Q}_k)^i (\mathbf{Q}_l)_i \quad \text{pour } k, l=1,2,3 \end{aligned} \quad (7-5)$$

From where:

$$\begin{cases} d\eta_k = (d\boldsymbol{\varepsilon})_j^i \cdot (\mathbf{Q}_k)^j (\mathbf{Q}_k)_i & \text{pour } k=1,2,3 \\ (\eta_k - \eta_l) \cdot (d\mathbf{Q}_k)^i (\mathbf{Q}_l)_i = (d\boldsymbol{\varepsilon})_j^i \cdot (\mathbf{Q}_k)^j (\mathbf{Q}_l)_i & \text{pour } k \neq l=1,2,3 \end{cases} \quad (7-6)$$

Let us note $\tilde{\varepsilon}_j^i$ mixed components of a tensor in the base $(\mathbf{Q}_k)_{k=1,2,3}$. Then:

$$\begin{cases} d\eta_k = (d\tilde{\varepsilon})_k^k & \text{pour } k=1,2,3 \text{ (pas de sommation sur } k) \\ (\eta_k - \eta_l) \cdot (d\mathbf{Q}_k)^i (\mathbf{Q}_l)_i = (d\tilde{\varepsilon})_l^k & \text{pour } k \neq l=1,2,3 \end{cases} \quad (7-7)$$

One checks obviously on the trace $\text{tr} \boldsymbol{\varepsilon} = \text{tr} \mathbf{Id} \otimes \boldsymbol{\varepsilon}$ tensor of the deformations (which is independent of the selected reference mark):

$$\sum_{k=1,2,3} d\eta_k = \text{tr}(d\tilde{\varepsilon}) = \text{tr}(d\boldsymbol{\varepsilon}) = d(\text{tr} \boldsymbol{\varepsilon}) \quad (7-8)$$

Let us consider the density of free energy of isotropic elasticity:

$$\phi(\boldsymbol{\varepsilon}) = \frac{1}{2} \lambda (\text{tr} \boldsymbol{\varepsilon})^2 + \mu \sum_{k=1,2,3} (\eta_k)^2 \quad (7-9)$$

then the law of state gives the tensor of the constraints:

$$\boldsymbol{\sigma} = \phi_{,\varepsilon}(\boldsymbol{\varepsilon}) = \lambda (\text{tr} \boldsymbol{\varepsilon}) \frac{d \text{tr} \boldsymbol{\varepsilon}}{d \boldsymbol{\varepsilon}} + \mu \sum_{k=1,2,3} \eta_k \frac{d \eta_k}{d \boldsymbol{\varepsilon}} = \lambda (\text{tr} \boldsymbol{\varepsilon}) \mathbf{Id} + 2\mu \sum_{k=1,2,3} \eta_k \cdot (\mathbf{Q}_k)^j (\mathbf{Q}_k)_i \cdot \mathbf{e}_j \otimes \mathbf{e}^{*i} \quad (7-10)$$

By applying the remark passed higher, the clean reference mark of the tensor of the constraints $\boldsymbol{\sigma}$ is thus identical to that of the deformations $\boldsymbol{\varepsilon}$.

The principal constraints are thus naturally in the principal reference mark $(\mathbf{Q}_k)^j \mathbf{e}_j$:

$$s_k = \tilde{\sigma}_k^k = \lambda \operatorname{tr}(\boldsymbol{\varepsilon}) + 2\mu \eta_k \quad (7-11)$$

8 Description of the versions of the document

Version Code_Aster	Author (S) Organization (S)	Description of the modifications
8.4	D.Markovic EDF-R&D/AMA	Initial text
9.5	S.Fayolle EDF-R&D/AMA	Rewriting of the equations and reformulations of certain sentences
9.6	F.Voldoire, S.Fayolle EDF-R&D/AMA	Corrections of equations and reformulation partial of the model; Re-drafting of the § 3 (identification of the parameters). Drafting of the appendix: demonstration of the derivation of the vclean aleurs.
10.1	F.Voldoire, S.Fayolle EDF-R&D/AMA	Some small corrections and complements.
10.2	F.Voldoire EDF-R&D/AMA	Modifications of the definition of the position of the reinforcements; addition of 3 internal variables, § 2.8.
11.1	F.Voldoire, S.Fayolle EDF-R&D/AMA	Addition of the methods of identification for <code>DEFI_GLRC</code> and of the coefficient α_c .
11.3	F.Voldoire EDF-R&D/AMA	Addition of a passage p. 11 explaining the slope in uniaxial load.
13.1	F.Voldoire EDF-R&D/AMA	Complements for the case $\alpha_c \neq 1$ in the sections of the § 3.2. Complements in thermomechanics.
14.3	A. Guilloux EDF-R&D/ERMES	Modifications of the parameter settings in inflection and compression