

SSNV199 – Cracking of a beam DCB with cohesive models

Summary:

This test makes it possible to model the propagation of a plane crack in a beam DCB (Double Beam Cantilever) three-dimensional rubber band with the following cohesive models:

- 1) finite elements of joint (modeling 3D_JOINT)
- 2) finite elements of interface (modeling 3D_INTERFACE).

Modeling a: Element of joint HEXA8 and cohesive law CZM_EXP_REG

Modeling b: Element of joint PENTA6 and cohesive law CZM_LIN_REG

Modeling C: Element of joint HEXA8 and cohesive law CZM_EXP_REG

Modeling D: Element of joint PENTA6 and cohesive law CZM_LIN_REG

Modeling E: Element of interface HEXA20 and cohesive law CZM_OUV_MIX

Modeling F: Element of interface PENTA15 and cohesive law CZM_OUV_MIX

Modeling G: Element of interface HEXA20 and cohesive law CZM_OUV_MIX

(idem that modeling E with initial crack with a grid)

The piloting of the loading by elastic prediction is also tested in all modelings. Local classification *ad hoc* cohesive elements is ensured by the order MODI_MAILLAGE and the keyword ORIE_FISSURE.

1 Problem of reference

1.1 Geometry and loading

In the Cartesian reference mark (X, Y, Z) one considers a beam DCB three-dimensional definite on the field $\Omega = [0, L] \times [-h, h] \times [0, b]$ of length $L = 20 \text{ mm}$, height $2h = 4 \text{ mm}$ and thickness $b = 6 \text{ mm}$, with an initial crack $\Gamma_0 = [0, a_0] \times \{0\} \times [0, b]$ of length $a_0 = 5 \text{ mm}$. One imposes on displacement u boundary conditions following:

$$u = U Y \quad \text{on the edge } \{0\} \times \{0^+\} \times [0, b]$$

$$u = -U Y \quad \text{on the edge } \{0\} \times \{0^-\} \times [0, b]$$

Taking into account symmetries of the problem, calculation is carried out on half of the structure (see figure 1.1-a). The grid of the half-beam is carried out with tetrahedral or hexahedral voluminal elements.

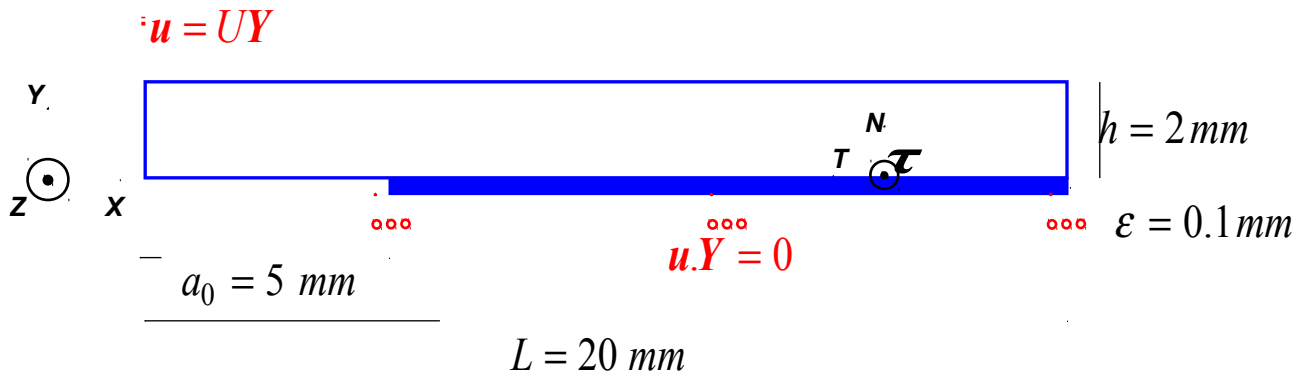

Figure 1.1-a : Diagram of beam DCB in the plan (X, Y) , boundary conditions and loading

The potential way of crack is with a grid by a layer of cohesive elements 3D (pentahedral or hexahedrons) nonworthless thickness¹ $\varepsilon = 0.1 \text{ mm}$ corresponding to the field $[a_0, L] \times [-\varepsilon/2, \varepsilon/2] \times [0, b]$. So the voluminal field of the beam is defined by $[a_0, L] \times [\varepsilon/2, h] \times [0, b]$. The loading is imposed $u = UY$ on stops $\{0\} \times [\varepsilon/2] \times [0, b]$ and the condition of symmetry $u \cdot Y = 0$ on the low part of the layer of joints: $[a_0, L] \times [-\varepsilon/2, h] \times [0, b]$.

¹ The local classification of the elements of this layer is carried out with the order ORIE_FISSURE. It is pointed out that this one requires that the elements do not have a worthless thickness.

2 Reference solution

There exists an approximate analytical solution with the mechanical problem presented in the preceding part. This one is based on the theory of the beams, it is valid for a slim structure $h \ll L$. The expression of kindness C DCB is given by:

$$C = U/F = \frac{a^3}{3EI}$$

where F indicate the force of reaction corresponding to imposed displacement U , a the length of the crack, $I = bh^3/12$ moment of inertia of the beam and b its thickness. The rate of refund of energy G associated with a crack length a is given by:

$$G = \frac{P^2}{2b} \frac{dC}{da} = \frac{9EI}{ba^4} U^2 \quad \text{éq 2-1}$$

For a stable propagation of crack one supposes the assumption of checked Griffith: $G = G_c$, which leads to the expression length of the crack a according to the loading U as well as the total answer of the beam:

$$a = \left(\frac{9EI}{bG_c} \right)^{1/4} U^{1/2}, \quad F = \frac{(EI)^{1/4} (bG_c)^{3/4}}{(3U)^{1/2}} \quad \text{éq 2-2}$$

Let us note however that the assumption $G = G_c$ is an approximation, owing to the fact that a cohesive model is used. This one is valid if the size of the cohesive zone² is small in front of the length of the crack. That amounts for the cohesive model taking a characteristic length $l_c = G_c/\sigma_c$ sufficient small.

3 Parameters material

The values of the Young modulus, of the Poisson's ratio, the critical stress and the tenacity of material are in the following way selected:

$$E = 100 \text{ MPa}, \quad \nu = 0, \quad \sigma_c = 3 \text{ MPa}, \quad G_c = 0.9 \text{ MPa.mm}$$

(NB: they are values "tests" which do not correspond to any material in particular)

Notice : The mechanical problem is symmetrized: one models only half of a crack (only one lip). The latter dissipates an energy twice less important than a complete crack. To model a material of tenacity given G_c , it is thus necessary to carry out simulation with a value of $G_c/2$.

² This zone corresponds to the zone of continuous transition between healthy material and the broken material, it does not exist with the approach of Griffith.

Warning : The translation process used on this website is a "Machine Translation". It may be imprecise and inaccurate in whole or in part and is provided as a convenience.

Copyright 2017 EDF R&D - Licensed under the terms of the GNU FDL (<http://www.gnu.org/copyleft/fdl.html>)

4 Modeling A

4.1 Characteristics of modeling

Simulation is carried out with modeling `3D_JOINT`. The elements are of type `HEXA8` for the elements of joint as for the voluminal elements. The cohesive law of behavior adopted is `CZM_EXP_REG`. The parameter of regularization of the law `PENA_ADHERENCE` is worth 10^{-5} . The voluminal elements are elastic.

4.2 Characteristics of the grid

One carries out a linear structured grid of the half-beam (figure below).

Voluminal elements (DCB): 216 `HEXA8`

Elements of joint (way of crack): 56 `HEXA8`

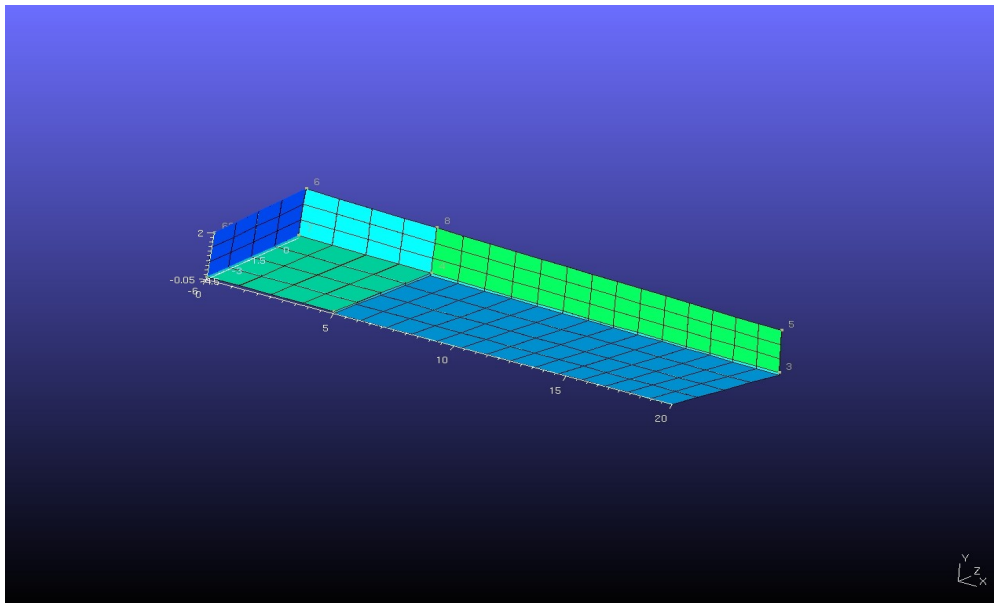

Figure 4.2-a : Diagram of the grid of the half beam, (the initial crack is not with a grid).

4.3 Sizes tested and results

Notice : Works on the approximate comparison of the solutions digital and analytical were completed in an internal note (cf H-T64-2007-0342). One will be satisfied here to provide the values of nonregression obtained with Code_Aster.

One notes F^R the resultant of the force corresponding to imposed displacement U .

Size tested	Code_Aster
U withmoment: 2	4.6061236901011D+00
F^R withmoment: 2	7.0451492319953D+00
U withmoment: 3	6.9693988127164D+00
F^R with Instant: 3	5.7661719205232D+00
U withmoment: 4	9.7548271517894D+00
F^R withmoment: 4	4.8584218510416D+00

5 Modeling B

5.1 Characteristics of modeling

Simulation is carried out with modeling 3D_JOINT. The elements are of type TETRA4 for the voluminal elements and PENTA6 for the elements of joint. The cohesive law of behavior adopted is CZM_EXP_REG. The parameter of regularization of the law PENA_ADHERENCE is worth 10^{-5} . The voluminal elements are elastic.

5.2 Characteristics of the grid

One carries out a linear grid not structured of the half-beam (figure below).

Voluminal elements (DCB): 3481 TETRA4
Elements joint (way of crack): 462 PENTA6

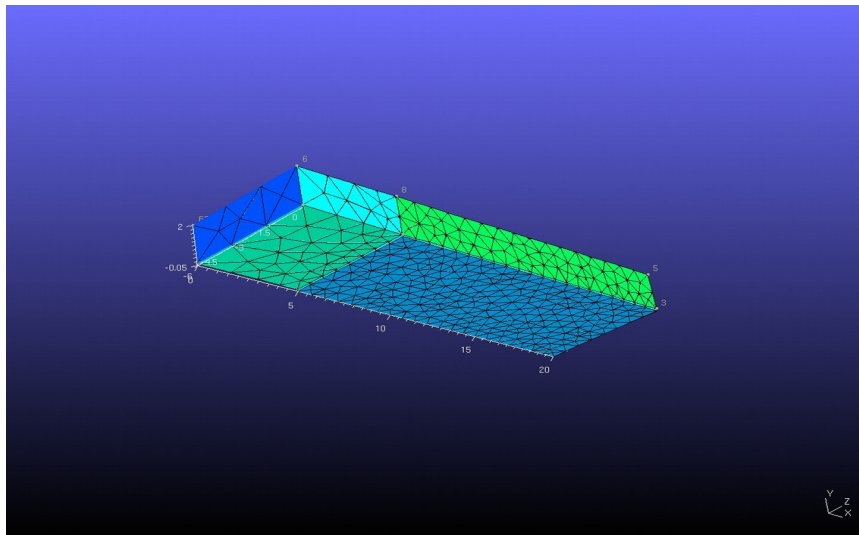

Figure 5.2-a : Diagram of the grid of the half beam, (the initial crack is not with a grid).

5.3 Sizes tested and results

Even notices that in paragraph 4.4.

One notes F^R the resultant of the force corresponding to imposed displacement U .

Size tested	Code_Aster
U withmoment: 2	4.0386002472857D+00
F^R withmoment: 2	7.9981249343083D+00
U withmoment: 3	6.1492839708222D+00
F^R with Instant: 3	6.5587957007180D+00
U withmoment: 4	8.6763623955462D+00
F^R withmoment: 4	5.5595526657741D+00

6 Modeling C

6.1 Characteristics of modeling

Simulation is carried out with modeling `3D_JOINT`. The elements are of type `HEXA8`, for the elements of joint as for the voluminal elements. The cohesive law of behavior adopted is `CZM_LIN_REG`. The parameter of regularization of the law `PENA_ADHERENCE` is worth 10^{-5} . The voluminal elements are elastic.

6.2 Characteristics of the grid

One carries out a linear structured grid of the half-beam (even grid that modeling A).

Voluminal elements (DCB): 216 `HEXA8`

Elements of joint (way of crack): 56 `HEXA8`

6.3 Sizes tested and results

Even notices that in paragraph 4.4.

One notes F^R the resultant of the force corresponding to imposed displacement U .

Size tested	Code_Aster
U withmoment: 2	4.6186712601876D+00
F^R withmoment: 2	7.1316429152946D+00
U withmoment: 3	6.9041423768554D+00
F^R with Instant: 3	5.8318660215042D+00
U withmoment: 4	9.6259568305961D+00
F^R withmoment: 4	4.9452238152838D+00

7 Modeling D

7.1 Characteristics of modeling

Simulation is carried out with modeling 3D_JOINT. The elements are of type TETRA4 for the voluminal elements and PENTA6 for the elements of joint. The cohesive law of behavior adopted is CZM_LIN_REG. The parameter of regularization of the law PENA_ADHERENCE is worth 10^{-5} . The voluminal elements are elastic.

7.2 Characteristics of the grid

One carries out a linear grid not structured of the half-beam (even grid that modeling B).

Voluminal elements (DCB): 3481 TETRA4

Elements of joint (way of crack): 462 PENTA6

7.3 Sizes tested and results

Even notices that in paragraph 4.4.

One notes F^R the resultant of the force corresponding to imposed displacement U .

Size tested	Code_Aster
U withmoment: 2	4.0193719091077D+00
F^R withmoment: 2	8.0668656941765D+00
U withmoment: 3	6.0660030864088D+00
F^R with Instant: 3	6.6762704371762D+00
U withmoment: 4	8.4416874805246D+00
F^R withmoment: 4	5.6476764257501D+00

8 Modeling E

8.1 Characteristics of modeling

Simulation is carried out with modeling `3D_INTERFACE` and of the elements of the type `HEXA20` for the elements of interfaces as for the voluminal elements. The cohesive law of behavior adopted is `CZM_OUV_MIX`. The parameter of penalization of the Lagrangian one `PENA_LAGR` is worth 10^2 , the rigidity of the slip `RIGI_GLIS` is worth 10. The voluminal elements are elastic.

8.2 Characteristics of the grid

One carries out a quadratic structured grid of the half-beam.
Voluminal elements (DCB): 216 `HEXA20`
Elements of interface (way of crack): 56 `HEXA20`

8.3 Sizes tested and results

Even notices that in paragraph 4.4.

One notes F^R the resultant of the force corresponding to imposed displacement U .

Size tested	Code_Aster
U withmoment: 2	5.00829D+00
F^R withmoment: 2	6.78854D+00
U withmoment: 3	6.97298 D+00
F^R with Instant: 3	5.75772 D+00
U withmoment: 4	9.12554 D+00
F^R withmoment: 4	4.93281 D+00

9 Modeling F

9.1 Characteristics of modeling

Simulation is carried out with modeling `3D_INTERFACE` and of the elements of the type `PENTA15` for the interfaces and `TETRA10` for the voluminal elements. The cohesive law of behavior adopted is `CZM_OUV_MIX`. The parameter of penalization of the Lagrangian one `PENA_LAGR` is worth 10^2 , the rigidity of the slip `RIGI_GLIS` is worth 10. The voluminal elements are elastic.

9.2 Characteristics of the grid

One carries out a quadratic grid not structured of the half-beam.

Voluminal elements (DCB): 3481 `TETRA10`

Elements of interface (way of crack): 462 `PENTA15`

9.3 Sizes tested and results

Even notices that in paragraph 4.4.

One notes F^R the resultant of the force corresponding to imposed displacement U .

Size tested	Code_Aster
U withmoment: 2	4.85116 D+00
F^R withmoment: 2	6.89090 D+00
U withmoment: 3	6.74636 D+00
F^R with Instant: 3	5.83393 D+00
U withmoment: 4	8.92820 D+00
F^R withmoment: 4	5.06475 D+00

10 Modeling G

10.1 Characteristics of modeling

Simulation is carried out with modeling `3D_INTERFACE` and of the elements of the type `HEXA20` for the elements of interfaces as for the voluminal elements.

The mechanical test is identical to modeling E. One changes only the grid: the initial crack is with a grid (see figure 10.2-a) and one initializes³ with "broken" the internal variables of the elements of interface located in this zone.

This modeling is used as example to the users. That can for example be useful when one wishes to define a face of crack which is not right (here it is right). In addition that makes it possible to take into account the contact on the initial crack what is not the case if this one is not with a grid with cohesive elements.

The cohesive law of behavior adopted is `CZM_OUV_MIX`. The parameter of penalization of the Lagrangian one `PENA_LAGR` is worth 10^2 , the rigidity of the slip `RIGI_GLIS` is worth 10. The voluminal elements are elastic.

10.2 Characteristics of the grid

One carries out a quadratic structured grid of the half-beam.

Voluminal elements (DCB): 216 `HEXA20`

Elements of interface, initial crack : 16 `HEXA20`, potential crack : 56 `HEXA20`

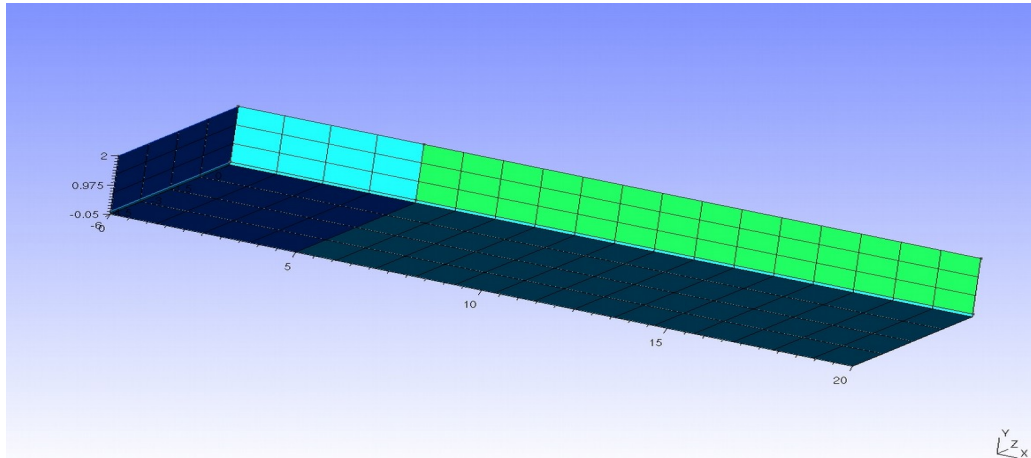

Figure 10.2-a : Diagram of the grid of the half beam, (the initial crack is with a grid).

10.3 Sizes tested and results

Even notices that in paragraph 4.4.

One notes F^R the resultant of the force corresponding to imposed displacement U . The same tests exactly are carried out that modeling E, the results are identical.

Size tested	Code_Aster
U with moment: 2	5.01006 D+00

³ starting from the order `CREA_CHAMP`

F^R withmoment: 2	6.78363 D+00
U withmoment: 3	6.97518 D+00
F^R with Instant: 3	5.75485 D+00
U withmoment: 4	9.13210 D+00
F^R withmoment: 4	4.93322 D+00

11 Summary of the results

The cohesive models of joint and interface predict a propagation of cracking all made correct taking into account the approximate analytical solution. That makes it possible to validate, partly, these types of models in 3D. For more details on the digital results, one can refer to internal note H-T64-2007-03420-FR.