

SSLV105 - Stiffening centrifuges of a beam in rotation

Summary:

Test of Mechanics of the structures in linear static analysis.

The geometry is that of a slim beam subjected to a rotation around one of its ends. 2 modelings: multifibre elements 3D (HEXA20) and beams. One tests here the inertial forces of rotation (like test SSLV104) with taking into account of the centrifugal stiffening.

The reference solution (analytical) takes into account the term of additional rigidity due to rotation. The results are identical to the reference solution.

1 Problem of reference

1.1 Geometry

The structure is made up of a directed slim beam carried in space by the axis of directing vector $(1, 1, 1)$.

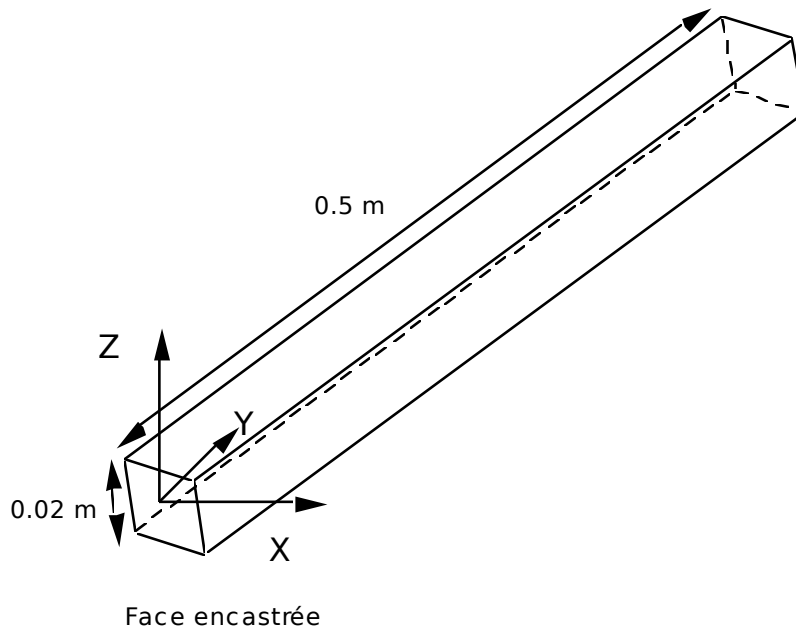

Square section of surface: $4.0 \cdot 10^{-4} m^2$

Length of the beam: $0.5 m$

1.2 Material properties

$$E = 2 \cdot 10^{11} Pa$$

$$\nu = 0$$

$$\rho = 7800 kg/m^3$$

1.3 Boundary conditions and loadings

Free beam fixed in rotation around an axis perpendicular to its greater dimension and passing by the center of the embedded face.

Coordinates of the vector rotation: $(1, 0, -1)$.

Number of revolutions: $\omega = 3000 rd/s$.

The important value number of revolutions does not have anything physics.

2 Reference solution

2.1 Method of calculating used for the reference solution

In local reference mark of the beam: the equation relating to displacement U_x (without neglecting lengthening) is:

$$\frac{\partial^2 U_x}{\partial x^2} + \frac{\rho}{E} \omega^2 (x + U_x) = 0$$

With the boundary conditions: $U_x(0) = 0$
 $\frac{\partial U_x}{\partial x}(L) = \sigma_{xx}(L) = 0$

One poses $\alpha = \sqrt{\frac{\rho \omega^2}{E}}$

By integrating the preceding differential equation one obtains, in the reference mark of the beam:

$$U_x(x) = \frac{\sin(\alpha x)}{\alpha \cos(\alpha L)} - x \quad U_y = U_z = 0$$

The displacement of any points of the beam is thus written in the total reference mark:

$$U_x(X, Y, Z) = \frac{1}{\sqrt{3}} \left(\frac{\sin(\alpha r)}{\alpha \cos(\alpha L)} - r \right)$$
$$U_y(X, Y, Z) = \frac{1}{\sqrt{3}} \left(\frac{\sin(\alpha r)}{\alpha \cos(\alpha L)} - r \right)$$
$$U_z(X, Y, Z) = \frac{1}{\sqrt{3}} \left(\frac{\sin(\alpha r)}{\alpha \cos(\alpha L)} - r \right)$$

with $r = \sqrt{X^2 + Y^2 + Z^2}$

2.2 Results of reference

Values of three displacements in the center of the section furthest away from the axis of rotation.

2.3 Uncertainty on the solution

Without object (analytical solution).

3 Modeling A

3.1 Characteristics of modeling

Elements 3D (HEXA20)

Maillage réglé comportant :
4 éléments sur la section
50 éléments sur la longueur
200 éléments au total

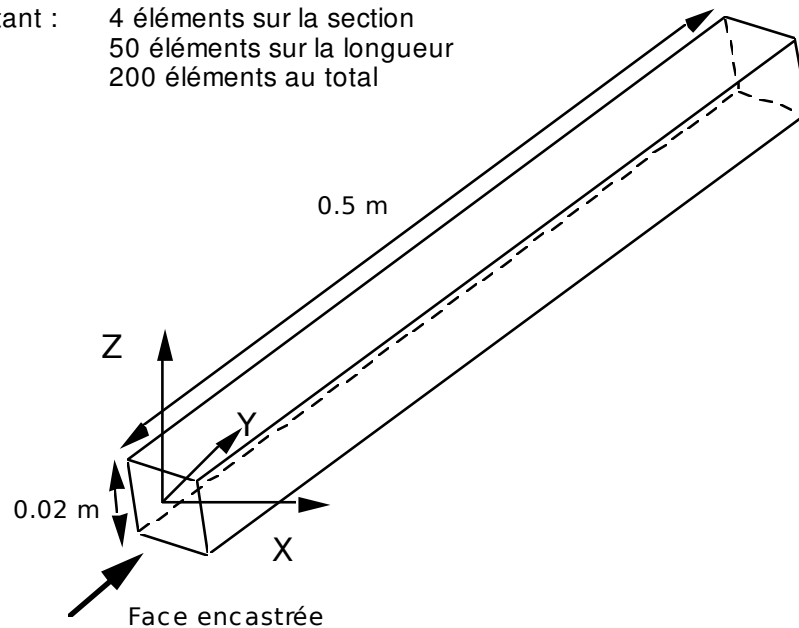

3.2 Characteristics of the grid

Many nodes: 1521

Many meshes and types: 200 HEXA20

3.3 Results

Identification	Type of reference	Value of reference	Tolerance (%)
DX in L	'ANALYTICAL'	$8.75 \cdot 10^{-3}$	0.1
DY in L	'ANALYTICAL'	$8.75 \cdot 10^{-3}$	0.1
DZ in L	'ANALYTICAL'	$8.75 \cdot 10^{-3}$	0.1

4 Modeling B

4.1 Characteristics of modeling

Multifibre elements Beams

4 fibres in the section
8 elements over the length

4.2 Characteristics of the grid

Many nodes: 9
Many meshes and types: 8 SEG2

4.3 Results

Identification	Type of reference	Value of reference	Tolerance (%)
DX in L	'ANALYTICAL'	$8.75 \cdot 10^{-3}$	3.E-5
DY in L	'ANALYTICAL'	$8.75 \cdot 10^{-3}$	3.E-5
DZ in L	'ANALYTICAL'	$8.75 \cdot 10^{-3}$	3.E-5

5 Summary of the results

Correct operation of the option `RIGI_ROTA`.

The beams with 8 elements give the solution to 2.10-5%. With only one element the error is only of 0.6%.

In comparison, the elements 3D with 200 elements give the solution to 0.01%.

This is due to the fact that the solution is integrated almost exactly with the beams.

To note the increase in axial displacement compared to the case without stiffening (SSLV104 [V3.04.104]).