

## SSNP109 - Cable of excentré prestressing in a right concrete beam

---

### Summary

One considers a right concrete beam, of rectangular section, crossed over his length by a cable of prestressed out of steel. The cable is right, parallel to average fibre of the beam, and passes to middle height of the section of the beam, while being excentré compared to the average plan. The left section of the beam and the left end of the cable are fixed. The cable is put in traction at its right end, in order to prestress the beam in inflection-compression. The losses of tension along the cable are neglected.

The goal of this CAS-test is to validate the method of calculating of the state of balance of a structure of concrete prestressed by comparison with an analytical reference solution.

## 1 Problem of reference

### 1.1 Geometry

The concrete beam is right, of rectangular section.

Its dimensions are:  $L \times h \times p = 10\text{ m} \times 0,4\text{ m} \times 0,2\text{ m}$  ( $y = h/2$ ).

The cable crosses the beam parallel with average fibre of the beam, with middle height. Its eccentricity compared to the average plan is  $e = 0,05\text{ m}$  ( $z = e$ ).

The surface of the cross-section of the cable is worth  $S_a = 1,5 \cdot 10^{-4}\text{ m}^2$ .

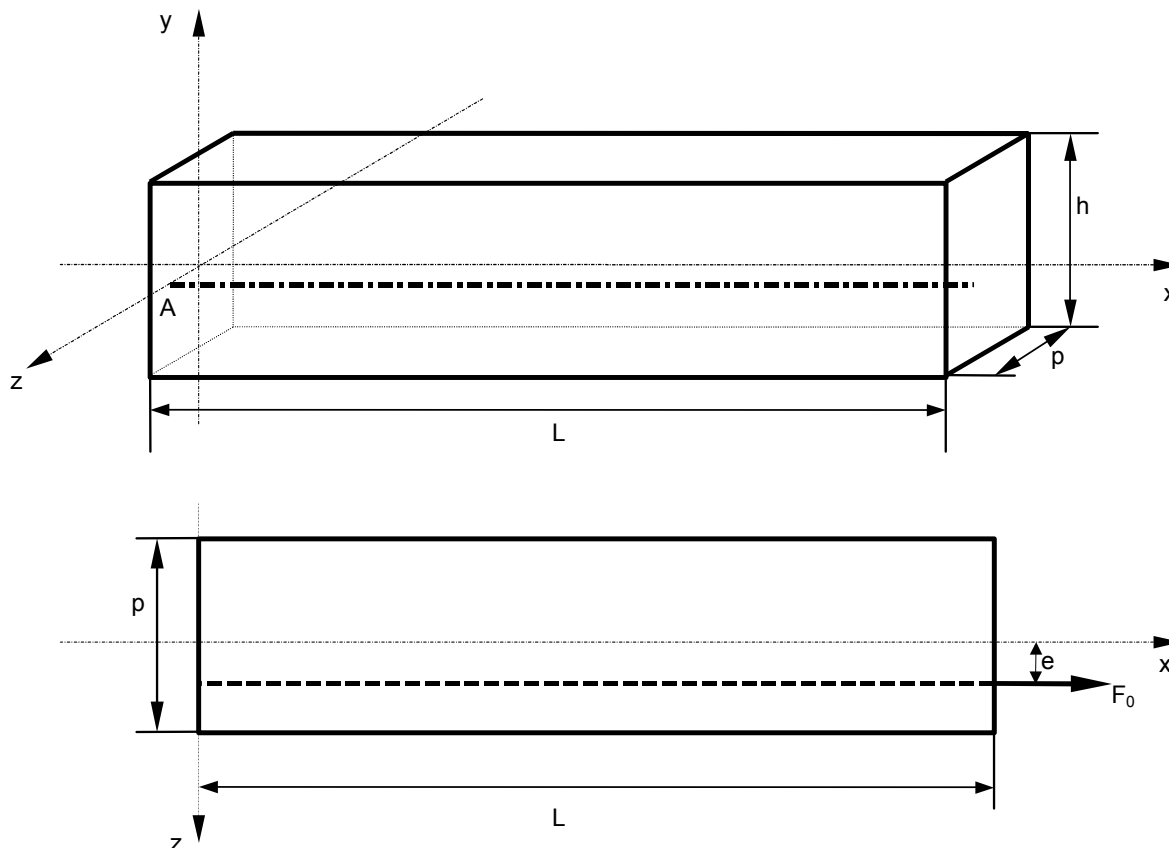

### 1.2 Properties of materials

Material concrete constituting the beam: Young modulus  $E_b = 3 \cdot 10^{10}\text{ Pa}$

Material steel constituting the cable: Young modulus  $E_a = 2,1 \cdot 10^{11}\text{ Pa}$

The Poisson's ratio is taken equal to 0 for two materials. One thus cancels the effects Fish in the directions  $y$  and  $z$ . Displacements have components only in the plan  $(x, z)$ .

The losses of tension in the cable being neglected, the various parameters being used for their estimate are fixed at 0.

### 1.3 Boundary conditions and loadings

The point  $A$  located in bottom of the left edge of the beam, coordinates  $(0 ; -h/2 ; 0)$ , is blocked in translation according to the three directions and rotation around the axis  $y$ .

The blocking of the degree of freedom of rotation  $DRY$  imply a worthless slope of the deformation of average fibre in  $x=0$ .

The left end of the cable, coordinates  $(0 ; 0 ; e)$ , is blocked in translation according to the three directions.

One applies at the right end of the cable, of coordinates  $(L ; 0 ; e)$ , a normal effort of traction  $(F_0 ; 0 ; 0)$  where  $F_0 = 2.10^5 N$ .

## 2 Reference solution

The analytical solution of reference is determined by the theory of the beams.

A embed-free beam is considered. The geometrical characteristics are those defined in paragraph [§2.1]. The prestressed cable applies at the loose lead a normal effort of compression  $(-F ; 0 ; 0)$  and a bending moment  $(0 ; -eF ; 0)$ .

The solution of this problem is the following one:

$$\text{Tensor of the constraints : } \sigma = \begin{pmatrix} \sigma_{xx} & 0 & 0 \\ 0 & 0 & 0 \\ 0 & 0 & 0 \end{pmatrix} \text{ with } \sigma_{xx} = -\frac{F}{hp} \left( 1 + \frac{12ez}{p^2} \right)$$

$$\text{Displacements: } \begin{cases} u(x, y, z) = -\frac{F}{E_b hp} \left( 1 + \frac{12ez}{p^2} \right) x \\ v(x, y, z) = \frac{\nu_b F}{E_b hp} \left( 1 + \frac{12ez}{p^2} \right) y + \frac{h}{2} \\ w(x, y, z) = \frac{F}{E_b hp} \nu_b z + \frac{6e}{p^2} x^2 - \nu_b y^2 - \frac{h^2}{4} - z^2 \end{cases}$$

$$\text{with boundary conditions : } \begin{cases} u = v = w = 0 \\ \theta_y = 0 \end{cases} \text{ en } x = 0, y = -\frac{h}{2}, z = 0$$

When the effects Fish are neglected ( $\nu_b = 0$ ), the solution in displacements is simplified as follows:

$$\begin{cases} u(x, y, z) = -\frac{F}{E_b hp} \left( 1 + \frac{12ez}{p^2} \right) x \\ v(x, y, z) = 0 \\ w(x, y, z) = \frac{F}{E_b hp} \times \frac{6ex^2}{p^2} \end{cases}$$

The digital values of reference are calculated using the analytical expressions above, while using for  $F$  the value with the overall balance of the normal effort in the cable:

$$F = -F_0 \frac{E_b hp}{E_b hp + E_a S_a \left( 1 + \frac{12e^2}{p^2} \right)}$$

## 3 Modeling A

### 3.1 Characteristics of modeling

The figure below gives a simplified representation of the grid of the beam.

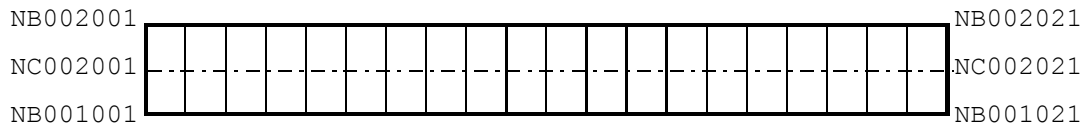

The concrete beam is represented by 20 elements of the type `DKT`, supported per as many meshes quadrangles to 4 nodes.

A thickness  $p=0,2m$  their is affected, as well as a material concrete for which the behaviors are defined `ELAS` (Young modulus  $E_b=3.10^{10} Pa$ ) and `BPEL_BETON`: the parameters characteristic of this relation are fixed at 0 because one neglects the losses of tension along the cable of prestressing.

Degrees of freedom  $DX$ ,  $DY$ ,  $DZ$  and  $DRY$  node `NB001001` are blocked.

The cable is represented by 20 elements `MECA_BARRE`, supported per as many meshes segments to 2 nodes. The ends left and right-hand side are respectively the nodes `NC001001` and `NC001021`.

A surface of cross-section  $S_a=1,5.10^{-4} m^2$  is assigned to the elements, as well as a material steel for which the behaviors are defined `ELAS` (Young modulus  $E_a=2,1.10^{11} Pa$ ) and `BPEL_ACIER`: the parameters characteristic of this relation are fixed at 0 (neglected losses of tension), except for the elastic ultimate stress for which the value of  $f_{prg}=1,77.10^9 Pa$  is selected.

Degrees of freedom  $DX$ ,  $DY$ , and  $DZ$  node `NC001001` are blocked.

The tension  $F_0=2.10^5 N$  is applied to the node `NC001021`. This value of tension is coherent with the values of section and yield stress, for a cable of prestressed of standard strand.

The calculation of the state of balance of the beam unit and cable is carried out in only one step, the behavior being elastic. One carries out then two complementary calculations allowing to determine the constraints in skins lower and higher ( $z=\pm p/2$ ) beam.

### 3.2 Stages of calculation and features tested

The principal stages of calculation correspond to the features which one wishes to validate:

- operator `DEFI_MATERIAU`: definition of the relations of behavior `BPEL_BETON` and `BPEL_ACIER`, in the typical case where the losses of tension along the cable of prestressing are neglected (values by default of the parameters);
- operator `DEFI_CABLE_BP`: determination of a constant profile of tension along the cable of prestressing, losses being neglected; calculation of the coefficients of the relations kinematics between the degrees of freedom of the nodes of the cable and the degrees of freedom of the nodes "close" to the beam out of concrete, in the case of a excentré cable;
- operator `AFFE_CHAR_MECA`: definition of a loading of the type `RELA_CINE_BP`;
- operator `STAT_NON_LINE`, option `BEHAVIOR`: calculation of the state of balance by taking account of the loading of the type `RELA_CINE_BP`.

One uses finally the operator `CALC_CHAMP` option `SIGM_ELNO` in order to calculate the constraints in lower skin then in higher skin of the beam.

### 3.3 Sizes tested and results

The value with the balance of the normal effort in the cable is  $F = 1,9550910^5 N$ . This value is used to calculate the digital results of reference using the analytical expressions clarified in paragraph [§3].

#### 3.3.1 Displacements of the nodes of the concrete part

One compares the values extracted the field DEPL resulting from STAT\_NON\_LINE with the theoretical values of reference corresponding to the plan  $Z=0$ .

The tolerance of relative variation compared to the reference is worth 0,1%.

Node	Component	Value of reference	Computed value	Relative variation
NB001006	DX	$-2,036552.10^{-4} m$	$-2,0365561834835.10^{-4} m$	$2,05.10^{-6} \%$
NB002006	DX	$-2,036552.10^{-4} m$	$-2,0365561835042.10^{-4} m$	$2,05.10^{-6} \%$
NB001011	DX	$-4,073104.10^{-4} m$	$-4,0731123669671.10^{-4} m$	$2,05.10^{-6} \%$
NB002011	DX	$-4,073104.10^{-4} m$	$-4,0731123670073.10^{-4} m$	$2,05.10^{-6} \%$
NB001016	DX	$-6,109656.10^{-4} m$	$-6,1096685504506.10^{-4} m$	$2,05.10^{-6} \%$
NB002016	DX	$-6,109656.10^{-4} m$	$-6,1096685505104.10^{-4} m$	$2,05.10^{-6} \%$
NB001021	DX	$-8,146208.10^{-4} m$	$-8,1462247339343.10^{-4} m$	$2,05.10^{-6} \%$
NB002021	DX	$-8,146208.10^{-4} m$	$-8,1462247340137.10^{-4} m$	$2,05.10^{-6} \%$
NB001006	DZ	$3,818535.10^{-3} m$	$3,8185428440476.10^{-3} m$	$2,05.10^{-6} \%$
NB002006	DZ	$3,818535.10^{-3} m$	$3,8185428440475.10^{-3} m$	$2,05.10^{-6} \%$
NB001011	DZ	$1,527414.10^{-2} m$	$1,5274171376197.10^{-2} m$	$2,05.10^{-6} \%$
NB002011	DZ	$1,527414.10^{-2} m$	$1,5274171376197.10^{-2} m$	$2,05.10^{-6} \%$
NB001016	DZ	$3,436682.10^{-2} m$	$3,4366885596448.10^{-2} m$	$1,91.10^{-6} \%$
NB002016	DZ	$3,436682.10^{-2} m$	$3,4366885596448.10^{-2} m$	$1,91.10^{-6} \%$
NB001021	DZ	$6,109656.10^{-2} m$	$6,1096695504804.10^{-2} m$	$2,05.10^{-6} \%$
NB002021	DZ	$6,109656.10^{-2} m$	$6,1096695504804.10^{-2} m$	$2,05.10^{-6} \%$

#### 3.3.2 Linear density of normal effort on the average level of the concrete part (analyzes with the model of plate)

One compares the values extracted the field SIEF\_ELNO resulting from STAT\_NON\_LINE with the theoretical values of reference.

The component to which the tests relate is  $N_{XX}$  ( $N_{XX} = s_{xx} p$ ).

The tolerance of relative variation compared to the reference is worth 0,1%.

Node	Mesh	Value of reference	Computed value	Relative variation
NB001001	QD001001	$-4,887725.10^5 N/m$	$-4,8877348399136.10^5 N/m$	$2,01.10^{-6} \%$
NB002001	QD001001	$-4,887725.10^5 N/m$	$-4,8877348399728.10^5 N/m$	$2,01.10^{-6} \%$
NB001011	QD001011	$-4,887725.10^5 N/m$	$-4,8877348402090.10^5 N/m$	$2,01.10^{-6} \%$
NB002011	QD001011	$-4,887725.10^5 N/m$	$-4,8877348402511.10^5 N/m$	$2,01.10^{-6} \%$
NB001021	QD001020	$-4,887725.10^5 N/m$	$-4,8877348403607.10^5 N/m$	$2,01.10^{-6} \%$
NB002021	QD001020	$-4,887725.10^5 N/m$	$-4,8877348404039.10^5 N/m$	$2,01.10^{-6} \%$

#### 3.3.3 Normal constraint on the lower skin (Z = - 0.1 m) of the concrete part

One compares the values extracted the field SIGM\_ELNO resulting from CALC\_CHAMP with the theoretical values of reference.

The component to which the tests relate is SIXX.

The tolerance of relative variation compared to the reference is worth 0,1%.

Node	Mesh	Value of reference	Computed value	Relative variation
NB001001	QD001001	1,221931.10 <sup>6</sup> Pa	1,2219337100849.10 <sup>6</sup> Pa	2,22.10 <sup>-6</sup> %
NB002001	QD001001	1,221931.10 <sup>6</sup> Pa	1,2219337101082.10 <sup>6</sup> Pa	2,22.10 <sup>-6</sup> %
NB001011	QD001011	1,221931.10 <sup>6</sup> Pa	1,2219337101212.10 <sup>6</sup> Pa	2,22.10 <sup>-6</sup> %
NB002011	QD001011	1,221931.10 <sup>6</sup> Pa	1,2219337100924.10 <sup>6</sup> Pa	2,22.10 <sup>-6</sup> %
NB001021	QD001020	1,221931.10 <sup>6</sup> Pa	1,2219337100302.10 <sup>6</sup> Pa	2,22.10 <sup>-6</sup> %
NB002021	QD001020	1,221931.10 <sup>6</sup> Pa	1,2219337101559.10 <sup>6</sup> Pa	2,22.10 <sup>-6</sup> %

### 3.3.4 Normal constraint on the higher skin (z= 0.1 m) of the concrete part

One compares the values extracted the field SIGM\_ELNO resulting from CALC\_CHAMP with the theoretical values of reference.

The component to which the tests relate is SIXX.

The tolerance of relative variation compared to the reference is worth 0,1%.

Node	Mesh	Value of reference	Computed value	Relative variation
NB001001	QD001001	- 6,109656.10 <sup>6</sup> Pa	- 6,1096685504454.10 <sup>6</sup> Pa	2,05.10 <sup>-6</sup> %
NB002001	QD001001	- 6,109656.10 <sup>6</sup> Pa	- 6,1096685505156.10 <sup>6</sup> Pa	2,05.10 <sup>-6</sup> %
NB001011	QD001011	- 6,109656.10 <sup>6</sup> Pa	- 6,1096685504816.10 <sup>6</sup> Pa	2,05.10 <sup>-6</sup> %
NB002011	QD001011	- 6,109656.10 <sup>6</sup> Pa	- 6,1096685504999.10 <sup>6</sup> Pa	2,05.10 <sup>-6</sup> %
NB001021	QD001020	- 6,109656.10 <sup>6</sup> Pa	- 6,1096685503914.10 <sup>6</sup> Pa	2,05.10 <sup>-6</sup> %
NB002021	QD001020	- 6,109656.10 <sup>6</sup> Pa	- 6,1096685505642.10 <sup>6</sup> Pa	2,05.10 <sup>-6</sup> %

## 3.4 Remarks

The computed values correspond indeed to those theoretically expected. One obtains well a state of inflection-compression for the concrete beam.

## 4 Synthesis

The got results are validated by comparison with an analytical solution of reference with a very good precision.

The particular features tested are the following ones:

- operator `DEFI_MATERIAU` : definition of the parameters characteristic of the materials steel and concrete allowing calculation of the tension along the cable of prestressing, following the rules of the BPEL;
- operator `DEFI_CABLE_BP` : calculation of the tension along the cable and the coefficients of the relations kinematics between the degrees of freedom of the nodes of the cable and the degrees of freedom of the nodes "close" to the concrete beam;
- operator `AFFE_CHAR_MECA` : definition of a loading of the type `RELA_CINE_BP` ;
- operator `STAT_NON_LINE`, option `BEHAVIOR` : calculation of the state of balance by taking account of the loading of the type `RELA_CINE_BP`.