

TPLP303 - Distribution of the temperature in the section of a conduit of chimney

Summary:

This test is resulting from the validation independent of version 3 in linear stationary thermics.

It is about a problem 2D plan represented by seven modelings mixing each one several types of elements.

The features tested are the following ones:

- thermal element plan,
- voluminal thermal element,
- limiting condition: convection.

The interest of the test lies in the mixture of different elements.

The results are compared with an analytical solution.

1 Problem of reference

1.1 Geometry

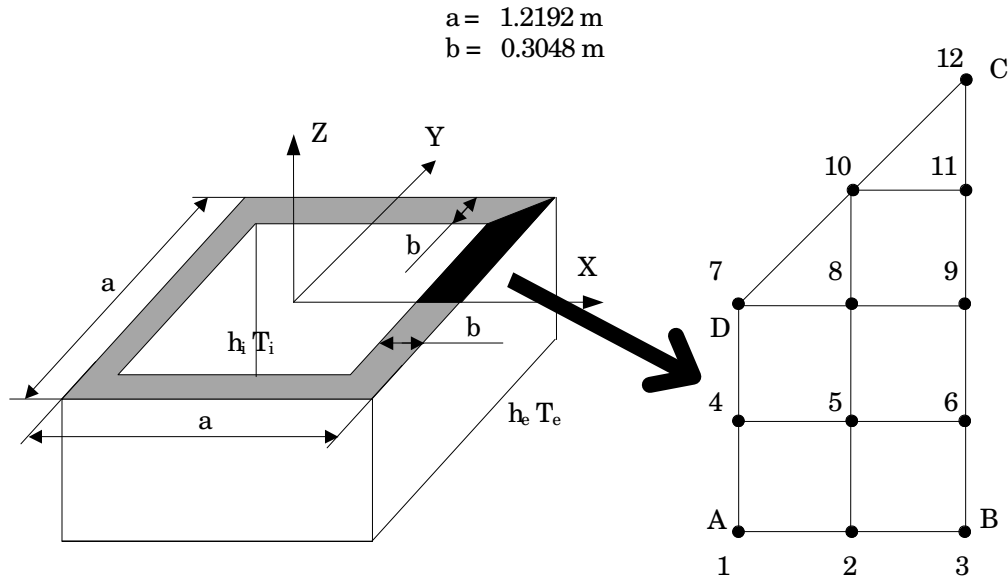

1.2 Properties of material

$\lambda = 1.7307 \text{ W/m}^\circ\text{C}$ Thermal conductivity

1.3 Boundary conditions and loadings

- Interior surface: $h_i = 68.135 \text{ W/m}^2\text{ }^\circ\text{C}$; $T_i = 37.78^\circ\text{C}$,
- External surface: $h_e = 17.034 \text{ W/m}^2\text{ }^\circ\text{C}$; $T_e = -17.78^\circ\text{C}$.

1.4 Initial conditions

Without object.

2 Reference solution

2.1 Method of calculating used for the reference solution

The original reference solution given in the book [bib1] is based on a method of relieving digital. This reference is quoted in the handbook of checking of ANSYS [bib2].

2.2 Results of reference

Temperature at the points $n^{\circ}1$ with 11 .

2.3 Uncertainty on the solution

Unknown factor, it was not possible to get the original reference (delivers old, more published).

2.4 Bibliographical references

1. Kreith, F., "Principles of heat transfer", International Textbook Co., Scranton, Pennsylvania, 2nd Printing, 1959.
2. ANSYS: "checking manual", 1st edition, June 1.1976

3 Modeling A

3.1 Characteristics of modeling

PLAN (TRIA3, QUAD4)

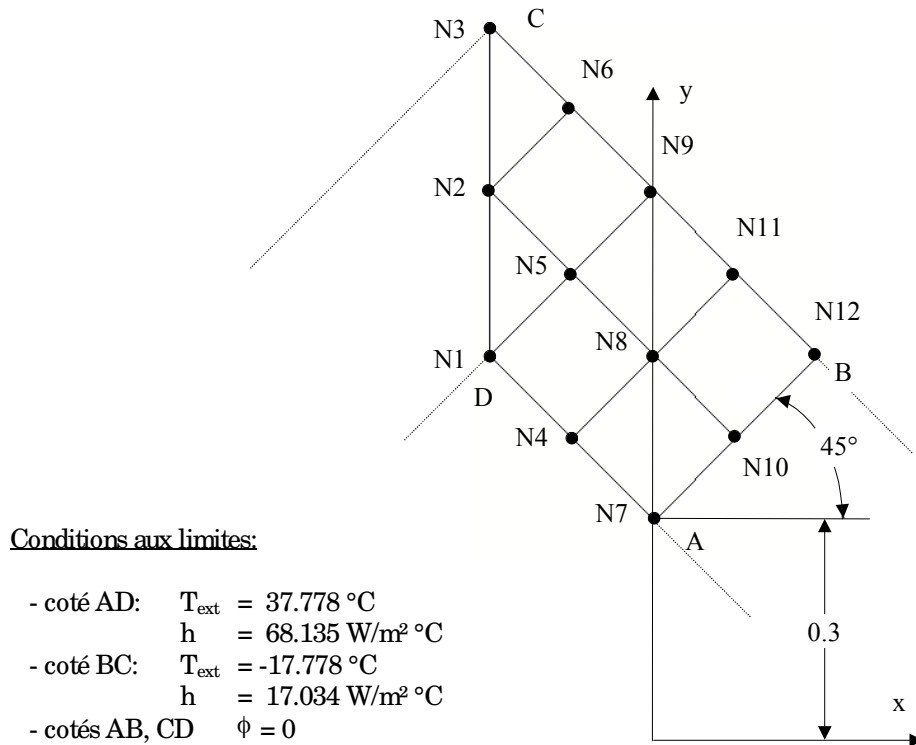

3.2 Characteristics of the grid

Many nodes: 12
Many meshes and types: 6 (5 QUAD4, 1 TRIA3)

3.3 Sizes tested and results

Identification	Reference	Relative variation %	Absolute deviation
		Tolerance	Tolerance
Temperature (°C)			
Points			
N1	30,889	4.0	2.0
N2	-1,333		2.0
N3	-15,167	6.0	1.0
N4	34,000	3.0	1.0
N5	8,611	1.0	1.0
N6	-11,278	5.0	1.0
N7	34,278	1.0	1.0
N8	12,556	2.0	1.0
N9	-7,611	8.0	1.0
N10	13,500	4.0	1.0
N11	-5,889	1.0	1.0
N12	-5,444	2.0	1.0

4 Complementary modelings B, C, D, E, F and G

Modeling *B* :

- Grid identical to that described in the card of modeling, on $1/8$ structure, but with quadratic elements,
- System of unit ($^{\circ}C, W, m, s$).

It is noted that the quadratic interpolation improves the results, the maximum change is of 49.16% for the value of reference nearest to 0.

Modeling *C* :

- Finer grid (22 QUAD8 + 4 TRIA6), on $1/8$ structure,
- System of unit ($^{\circ}C, W, m, s$).

One notes that compared to modeling *B*, the maximum change does not decrease but increases (54.58%).

Modeling *D* :

- Grid identical to that described in the card of modeling, on $1/8$ structure,
- System of English unit ($^{\circ}F, Btu, feet, hr$).

It is noted that the maximum relative variation decreases in an important way (-33.29%), this variation is not located any more at the same place. On the other hand it is always located on the value of reference nearest to 0.

Modeling *E* :

- Grid identical to that described in the card of modeling, on $1/8$ structure, but with quadratic elements,
- System of English unit ($^{\circ}F, Btu, feet, hr$).

It is noted that the quadratic elements improve the results by with a linear modeling (maximum change of -6.5%).

Modeling *F* :

- cutting identical to that described in the card of modeling (12 QUAD4) but on $1/4$ structure,
- System of English unit ($^{\circ}F, Btu, feet, hr$).

It is noted that this grid with linear elements (without TRIA3) is much more precise, the maximum change is of -5.27% .

Modeling *G* :

- Cutting identical to that described in the card of modeling, but on $1/4$ structure and with quadratic elements,
- System of English unit ($^{\circ}F, Btu, feet, hr$).

It is noted that this grid (without TRIA3) is much less precise than at the time of modeling *F*, the maximum change is of -6.26% .

5 Results of modelings B, C, D, E, F and G

On the figure below we present the points of observation (for more details to see the corresponding test probe).

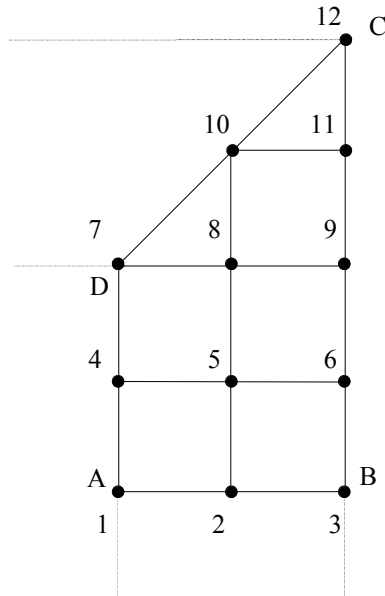

In the tables presented below we give for each modeling the results got with *Code_Aster*, like for modeling *A* results got with code NISA (calculations carried out by Mr. CLERK EDF/DER/ADE). We grayed the upper deviations than the tolerance (2%).

Calculations carried out in $w, m, ^\circ C$

Points	Modélisation With		Modeling B	Modeling C	Modeling With	
	Ref.	Tolérance%	Tolerance %	Tolerance %	NISA	Variation %
1	34,278	1.0	1.0	1.0	34,114	- 0,480
2	13,500	4.0	2.0	2.0	13,973	3,506
3	- 5,444	2.0	6.0	5.0	- 5,377	- 1,229
4	34,000	3.0	1.0	1.0	34,718	2,111
5	12,556	2.0	4.0	4.0	12,716	1,274
6	- 5,889	1.0	7.0	7.0	- 5,909	0,336
7	30,889	4.0	5.0	6.0	29,795	- 3,541
8	8,611	1.0	19.0	19.0	8,566	- 0,518
9	- 7,611	8.0	9.0	10.0	- 8,152	7,111
10	- 1,333	150.0	50.0	67.0	- 2,528	89,632
11	- 11,278	5.0	3.0	3.0	- 10,810	- 4,152
12	- 15,167	6.0	1.0	1.0	- 16,036	5,729

Calculations carried out in *Btu, feet, °F*

Points	Ref.	Modeling D	Modeling E	Modeling F	Modeling G
		Tolérance%	Tolérance%	Tolérance%	Tolérance%
1	93.7	1.0	1.0	1.0	1.0
2	56.3	2.0	1.0	2.0	1.0
3	22.2	1.0	2.0	1.0	2.0
4	93.2	2.0	1.0	2.0	1.0
5	54.6	1.0	2.0	1.0	2.0
6	21.4	1.0	4.0	3.0	4.0
7	87.6	3.0	3.0	9.0	3.0
8	47.5	1.0	6.0	6.0	7.0
9	18.3	6.0	7.0	6.0	6.0
10	29.6	8.0	4.0	2.0	6.0
11	11.7	8.0	5.0	2.0	4.0
12	4.7	34.0	5.0	3.0	5.0

From these 7 analyses, we can make the following observations:

- grid suggested in the test probe (5 QUAD4 + 2 TRIA3) is not adapted. To approach the reference solution there are two possibilities:
 - to use the quadratic grid on $1/8$ structure,
 - to use a linear grid without triangle on $1/4$ structure,
- the choice of the system of unit to important considerable in the calculation of the relative variation,
- for same modeling (*A*) the results enters *Code_Aster* and NISA are identical.

6 Summary of the results

The modeling carried out on 1/8 structure gives results of which many values exceed the tolerance fixed initially (2%). The maximum change obtained is of 89% , it is located on the smallest value of reference. The analysis of the isotherms shows that those are not perpendicular to the right-hand side DC , the condition of symmetry is not observed.

To find an explanation to these important differences, several complementary modelings were carried out (cf annexes B). The conclusions are the following ones:

- change of the system of units ($^{\circ}C \rightarrow ^{\circ}F$) allows to decrease the maximum change with a value of 33% ,
- modeling with quadratic elements (and in $^{\circ}F$) improve the results, the maximum change is of 6.8% ,
- the modeling of one 1/4 structure with only of QUAD4 (and in $^{\circ}F$) improve the results, the maximum change is of -5.27% ,
- modeling A , carried out with software NISA, gives results identical to those of *Code_Aster*.

Moreover, it was not possible to get the original reference (delivers of Kreith) quoted in the handbook of checking of ANSYS. The method of acquisition of the reference solution and its uncertainty are thus not known.

The results are regarded as acceptable taking into account evoked points C_i - above. However it will be necessary to search complementary elements on the reference solution.